

TROUBLESHOOTING CHART:

Problem	Cause	Solution
1. No discharge	a. No water b. Magnetic valve not functioning c. Excessive water pressure d. Eductor clogged	a. Open water supply b. Install valve parts kit c. Install regulator if water pressure exceeds 85 PSI d. Clean* or replace
2. No concentrate draw	a. Clogged foot valve b. Metering tip or eductor has scale build-up c. Low water pressure d. Discharge tube and/or flooding ring not in place e. Concentrate container empty f. Inlet stub not screwed into eductor tightly g. Clogged water inlet strainer h. Selector out of position	a. Clean or replace b. Clean (descale)* or replace c. Minimum 25 PSI (with water running) required to operate unit properly d. Push tube firmly onto eductor discharge hose barb; replace tube if it doesn't have a flooding ring e. Replace with full container f. Tighten, but do not overtighten g. Disconnect inlet water line and clean strainer h. Assure selector is in position desired
3. Excess concentrate draw	a. Metering tip not in place b. Orifice seals not secure	a. Press correct tip firmly into hose barb b. Assure proper sealing in selector valve
4. Failure of unit to turn off	a. Water valve parts dirty or defective b. Magnet doesn't fully return c. Push button stuck d. Excessive water pressure	a. Clean* or replace with valve parts kit b. Make sure magnet moves freely. Replace spring if short or weak c. Realign cabinet or clean grommet that button passes through d. Install regulator if pressure exceeds 85 PSI

* In hard water areas, scale may form inside the discharge end of the eductor, as well as in other areas of the unit that are exposed to water. This scale may be removed by soaking the eductor in a descaling solution (deliming solution). To remove an eductor located in the cabinet, firmly grasp vacuum breaker and unthread eductor. Replace in same manner. This will avoid loosening the vacuum breaker. Alternatively, a scaled eductor can be cleaned (or kept from scaling) by drawing the descaling solution through the unit. Operate the unit with the suction tube in the descaling solution. Operate the unit until solution is drawn consistently, then flush the unit by drawing clear water through it for a minute. Replace concentrate container and put suction tube into concentrate.



MaxiMizer™ II Proportioning System
Models 28711 & 28721

Package Contains:

- | | |
|---------------------------|---------------------------------|
| 1. Proportioner unit. | 5. Metering tip kits. |
| 2. Supply tubes. | 6. Mounting anchor kit. |
| 3. Foot valve and weight. | 7. Drip tray (Model 28721 only) |
| 4. Discharge tubes. | 8. Instruction sheet. |

THANK YOU FOR YOUR INTEREST IN OUR PRODUCTS

Hydro Systems manufactures quality chemical proportioning equipment. Please use this equipment carefully and observe all warnings and cautions.

***** NOTE *****

WEAR	protective clothing and eyewear when dispensing chemicals or other materials.
ALWAYS	observe safety and handling instructions of the chemical manufacturers.
ALWAYS	direct discharge away from you or other persons or into approved containers.
ALWAYS	dispense cleaners and chemicals in accordance with manufacturer's instructions. Exercise CAUTION when maintaining your equipment.
KEEP	equipment clean to maintain proper operation.
WEAR	protective clothing and eyewear when working in the vicinity of all chemicals, filling or emptying equipment or changing metering tips.
ALWAYS	re-assemble equipment according to instruction procedures. Be sure all components are firmly screwed or latched into position.
ATTACH	only to tap water outlets (85 PSI maximum).
NOTE	If the unit is used to fill a sink or the discharge hose can be placed into a sink, the unit must be mounted so that the bottom of the cabinet is above the overflow rim of the sink.

Installation and Operation:

- Unlock the front door panel and open it. The top panel can be removed for easier access: loosen the screws at the bottom edge.
- To mount the unit to a wall, drill mounting holes and insert the plastic toggle anchors provided into the holes. Use the screws provided to secure the unit to the wall.
- Connect water supply hose of at least 1/2" ID to water inlet swivel at right side of manifold. (Minimum 25 PSI pressure, with water running, is required for proper operation.) Route hose out the side of the cabinet, through the hole provided, and attach the hose to the water supply source. Turn water supply on.
- For Model 28711:* Connect the long, flexible discharge tube to the bottom of the 4 GPM (yellow) eductor, applying the end opposite the hook. Route the hose out the bottom of the unit, through the hole provided. The hook allows the discharge tube to hang neatly when not in use. Make sure discharge tube is fully engaged onto the eductor.
For Model 28721: A short, discharge tube has already been installed on the grey eductor. Make sure discharge tube is fully engaged onto the eductor.
- Select metering tips (up to 4) for the selector valve (see next two sections). Push each tip firmly into a separate hose barb extending from the selector valve. A tip with no hole (clear plastic color) can be used to block any valve port not being used. (This may be used for dispensing water only.)
- Rig the suction tube assembly as follows:
 - Put the 1/4" x 2 1/2" tubes on the selector valve barbs.
 - Install "Y" fitting to join the two 2 1/2" tubes on the right side of the selector valve so that the single leg of the "Y" points away from the selector valve. Install a second "Y" fitting in the same manner on the left side of the selector valve.
 - Install one of the 6" pieces of tubing on the right "Y" fitting and the other on the left "Y" fitting.
 - Install the remaining "Y" fitting between the two pieces of tubing to connect them.
 - From the 2' piece of tubing, cut a piece that will reach from the "Y" fitting to the bottom of the concentrate container when it's in place in the cabinet. Install this piece of tubing on the bottom leg of the "Y" fitting, then slide a weight over the open end of the tube. Put the foot valve hose barb into the open end of the tube.
- Place foot valve end of suction tube into the concentrate container and put container into MaxiMizer cabinet.
 - REMEMBER TO CHECK FOOT VALVE STRAINER FOR CLOGGING PERIODICALLY. CLEAN AS NECESSARY.
- Close front door panel and lock. For Model 28721, be sure the drip tray is in its place at the bottom of the shelf, below concentrate container.
- Write product dilutions or uses on the label that has been pre-applied to the system cabinet so that they correspond to the selector positions.
- Turn knob to select desired product. Push button to start flow of desired water/concentrate solution, and hold until supply tube is primed (filled). (Be sure to have a bottle or other receptacle under the discharge tube.) Prime each tube in the same fashion. Push the button whenever dispensing is desired. Release button to stop flow of solution. Button on Model 28711 may be converted to twist-to-latch locking button by installing the latch spring provided (see parts diagram for placement). This allows continuous dispensing without holding button.

Metering Tip Selection:

The final concentration of the dispensed liquid is related to both the size of the metering tip opening and the viscosity of the liquid being siphoned. If product viscosity is noticeably greater than that of water, consult the procedure for Measurement of Concentration on the next page to achieve your desired water-to-product ratio. For water-thin products, use the chart on the next page as a **guideline**. Use undrilled, clear tip for drilling orifices to sizes not listed, or as a plug for ports not used.



A DOVER RESOURCES COMPANY

Hydro Systems 3798 Round Bottom Road, Cincinnati, OH 45244 s Phone: (513) 271-8800 s Fax: (513) 271-0160

10089665
REV. A 3/10

Measurement of Concentration:

You can determine the dispensed water-to-product ratio for any metering tip size and product viscosity. All that is required is to operate the primed dispenser for a minute or so and note two things: the amount of dispensed solution, and the amount of concentrate used in preparation of the solution dispensed. The water-to-product ratio is then calculated as follows:

$$\text{Dilution Ratio (X:1) where } X = \frac{\text{Amount of Mixed Solution} - \text{Amount of Concentrate Drawn}}{\text{Amount of Concentrate Drawn}}$$

Dilution Ratio, then, equals X parts water to one part concentrate (X:1). If the test does not yield the desired ratio, choose a different tip and repeat the test. Alternative methods to this test are 1) pH (using litmus paper), and 2) titration. Contact your concentrate supplier for further information on these alternative methods and the materials required to perform them.

MaxiMizer II Parts Diagrams/List:

APPROXIMATE DILUTIONS AT 40 PSI FOR WATER-THIN PRODUCTS (1.0 CP)				
Tip Color	Orifice Size	Std. Drill Number	Ratio (per Eductor Flow)	
			1 GPM	3.5 GPM
No Tip	.187	(3/16)	3:1	6.5:1
Grey	.128	(30)	3:1	6.5:1
Black	.098	(40)	3:1	7:1
Beige	.070	(50)	4:1	10:1
Red	.052	(55)	5:1	16:1
White	.043	(57)	7:1	20:1
Blue	.040	(60)	8:1	24:1
Tan	.035	(65)	10:1	30:1
Green	.028	(70)	16:1	45:1
Orange	.025	(72)	20:1	56:1
Brown	.023	(74)	24:1	64:1
Yellow	.020	(76)	32:1	90:1
Aqua	.018	(77)	38:1	128:1
Purple	.014	(79)	64:1	180:1
Pink	.010	(87)	128:1	350:1

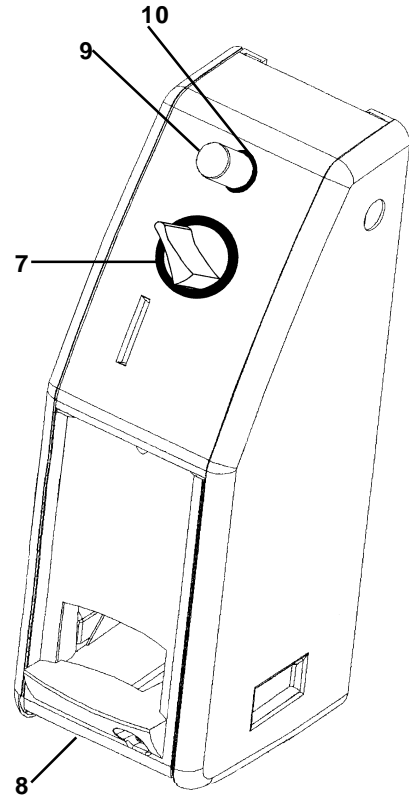
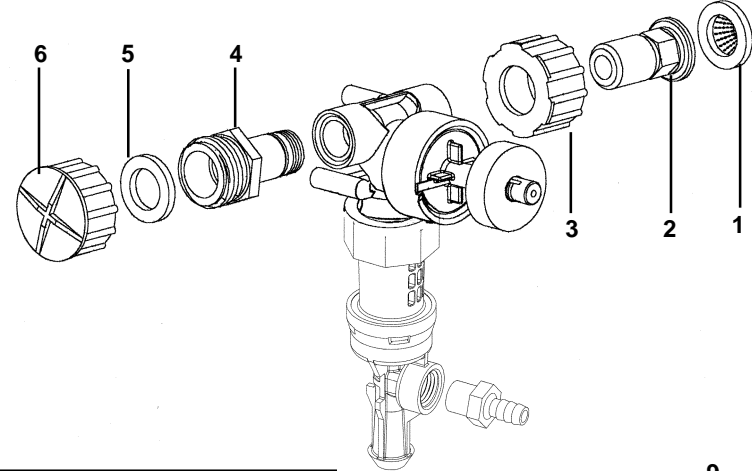

Key	Part No.	Description
1	238100	Strainer washer
2	10082801	Swivel stem
3	10082830	Swivel collar
4	10082821	Connector fitting
5	10069260	Washer
6	10082840	Fitting cap
7	10020700	Grommet for selector valve
	10020900	Retainer for selector valve grommet
8	10075160	Drip tray (Model 2872-2 only)
9	10077480	Button, dark grey (includes #10)
	10077481	Button, blue (includes #10)
	10077482	Button, red (includes #10)
	10077483	Button, green (includes #10)
	10077484	Button, yellow (includes #10)
	10077485	Button, light grey (includes #10)
	10082750*	Button, dark grey locking
	10082751*	Button, blue locking
	10082752*	Button, red locking
	10082753*	Button, green locking
	10082754*	Button, yellow locking
	10082755*	Button, light grey locking
		* Locking button parts kits include grommet and latch spring (#14)
10	10068810	Grommet

MaxiMizer II Parts Diagrams/List:

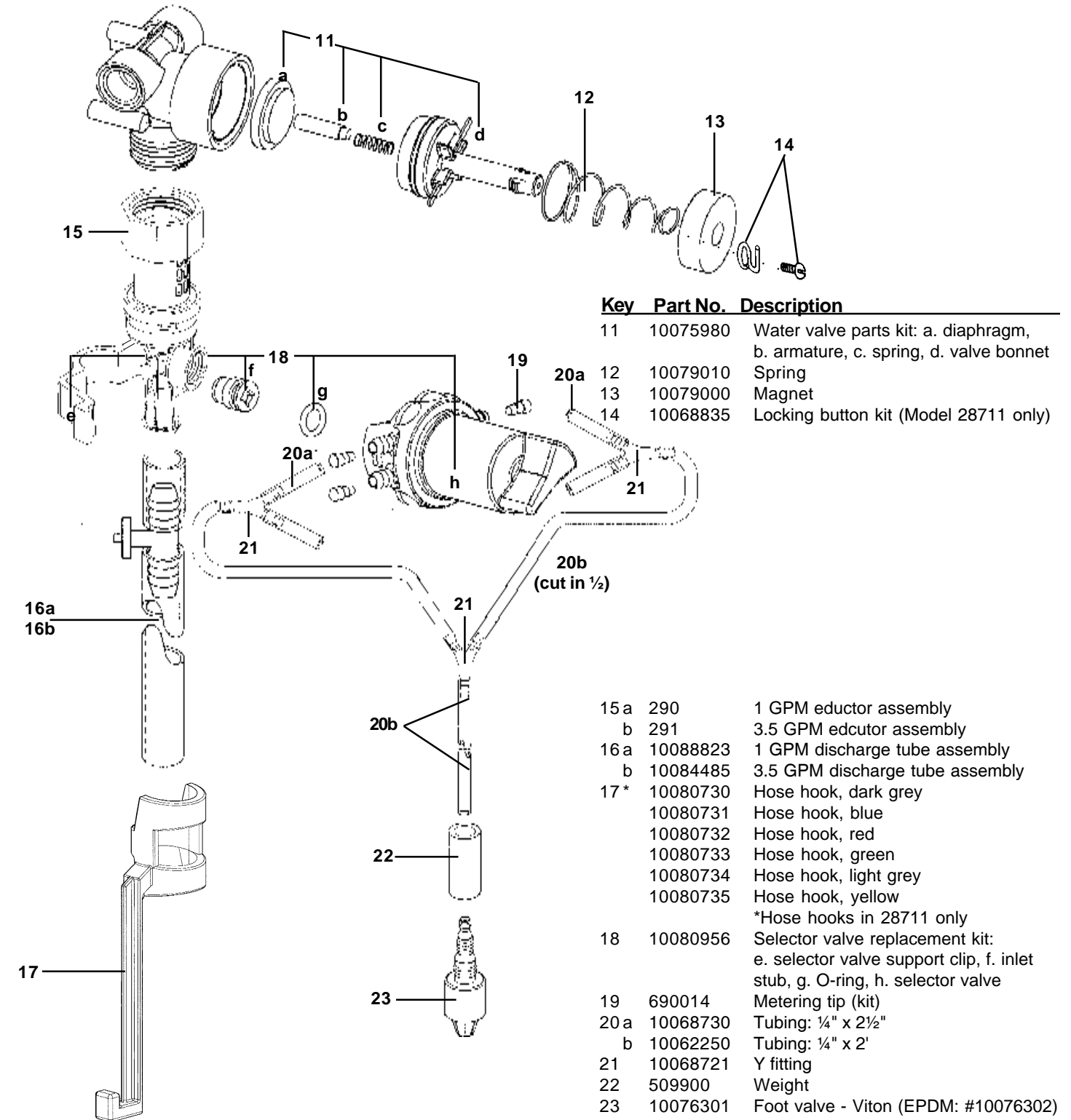

Key	Part No.	Description
11	10075980	Water valve parts kit: a. diaphragm, b. armature, c. spring, d. valve bonnet
12	10079010	Spring
13	10079000	Magnet
14	10068835	Locking button kit (Model 28711 only)

15 a	290	1 GPM eductor assembly
b	291	3.5 GPM eductor assembly
16 a	10088823	1 GPM discharge tube assembly
b	10084485	3.5 GPM discharge tube assembly
17*	10080730	Hose hook, dark grey
	10080731	Hose hook, blue
	10080732	Hose hook, red
	10080733	Hose hook, green
	10080734	Hose hook, light grey
	10080735	Hose hook, yellow
		*Hose hooks in 28711 only
18	10080956	Selector valve replacement kit: e. selector valve support clip, f. inlet stub, g. O-ring, h. selector valve
19	690014	Metering tip (kit)
20 a	10068730	Tubing: 1/4" x 2 1/2"
b	10062250	Tubing: 1/4" x 2"
21	10068721	Y fitting
22	509900	Weight
23	10076301	Foot valve - Viton (EPDM: #10076302)
NOT SHOWN:		
	10075150	Lock
	10029509	Nut for lock
	10075128	Keys for lock (2)
	10075158	MSDS Envelope
	10068885	Hole plug (for cabinet openings)