



HydroMinder Models 561 & 562

PACKAGE CONTAINS:

- | | |
|---|------------------------------------|
| 1. Proportioner (Model 562 includes siphon breaker) | 5. Discharge tube assembly - 2 ft. |
| 2. Bracket for mounting | 6. Metering tip kit |
| 3. Float with chain | 7. Product information sheet |
| 4. Supply tube with foot valve - 9 ft. | |

THANK YOU FOR CHOOSING OUR PRODUCTS

Hydro Systems manufactures quality chemical proportioners. Please use this equipment carefully and observe all warnings and cautions.

NOTE

- | | |
|---------------|--|
| WEAR | protective clothing and eyewear when working in the vicinity of all chemicals, filling or emptying equipment, or changing metering tips. |
| ALWAYS | <p>observe safety and handling instructions of the chemical manufacturers.</p> <p>direct discharge away from you or other persons or into approved containers.</p> <p>dispense cleaners and chemicals in accordance with manufacturer's instructions.</p> <p>exercise CAUTION when maintaining your equipment. Re-assemble equipment according to instruction procedures. Be sure all components are firmly screwed or latched into position.</p> |
| CLEAN | equipment after each use in accordance with instruction sheet. |
| ATTACH | only to tap water outlets (85 PSI maximum). |

Through proper care and maintenance, this equipment will serve your toughest cleaning jobs.

INSTALLATION:

1. Select a metering tip (see next section) and install it into the suction stub on the eductor body.
2. Attach the end of the discharge tube with the clamp and flooding ring to the discharge barb on the eductor. On Model 561 (without siphon breaker), you may want to drill a small hole (1/8" or 1/4" ID) in the discharge tube, above the highest solution level point and below the discharge end of the eductor. This will allow the discharge tube to drain after each cycle.
3. Mount the unit in a level position on the side of a reservoir. If necessary, reposition or remove the mounting bracket.
4. Insert foot valve end of suction tube into concentrate container. Cut the tube to the length required so that the tube goes just to the bottom of the concentrate container. (Level of concentrate in the container must be below the discharge point of the installed unit, or the HydroMinder will continue to siphon concentrate after it is turned off.)
5. Slide the open end of the suction tube over the suction stub.
6. Adjust chain length to position float at the desired highest level of solution. To prevent foaming, be certain that the point of discharge will be below the solution level at its lowest point.
NOTE: HydroMinder Models 561 & 562 are designed to shut off slowly to help reduce water hammer. Be sure to take this into account when setting the high water level to prevent inadvertent tank overflow. Be sure float mechanism is not hampered by water turbulence caused by discharging solution. It may be necessary to baffle the float from the discharge in order for the unit to work properly.
7. Install minimum 3/4" ID hose to the HydroMinder valve. Minimum 25 PSI pressure (flowing water) required at valve inlet.

NOTE: Maximum water temperature 120 degrees fahrenheit.

OPERATION:

Open the water supply valve. When the solution in the reservoir reaches the level set by the float, the valve will close. This will stop the water flow and siphoning of concentrate. When withdrawal of solution from the reservoir causes the level to drop, the valve will open and the reservoir will be refilled to the previous level. This cycle will be repeated automatically until the supply of concentrate is depleted. The water supply valve should be **fully closed** when changing metering tips, when reservoir is drained, or when the unit is not in use.



Hydro Systems 3798 Round Bottom Road, Cincinnati, OH 45244 Phone: (513) 271-8800 Fax: (513) 271-0160

10091731
Rev. A 3/07

METERING TIP SELECTION:

Because dilutions vary with application and situation, always test your actual, achieved dilution using the Measurement of Concentration procedure on the next page. Use the chart below as a guideline to tip selection when product concentrate is of water-thin viscosity. Two undrilled, clear tips are supplied for drilling sizes not listed.

Tip Color	Nominal Diameter	Approx. Dilution Ratio at 40 PSI, Water-thin Viscosity (1.0 cp)	For reference: Ounces/gallon
No tip	Open connector	6.5:1	
Grey	.128	12:1	
Black	.098	20:1	8:1 = 16 oz./gal.
Beige	.070	38:1	
Red	.052	68:1	16:1 = 8 oz./gal.
White	.043	95:1	
Blue	.040	105:1	32:1 = 4 oz. gal.
Tan	.035	130:1	
Green	.02	180:1	64:1 = 2 oz./gal.
Orange	.025	270:1	
Brown	.023	310:1	128:1 = 1 oz./gal.
Yellow	.020	380:1	
Purple	.014	610:1	256:1 = 1/2 oz./gal.
Pink	.010	1200:1	

MEASUREMENT OF CONCENTRATION:

You can determine the dispensed water-to-product ratio for any metering tip size and product viscosity. All that is required is to operate the primed dispenser for a minute or so and note two things: the amount of dispensed water/product mixture, and the amount of concentrate used in preparation of the solution dispensed. The water-to-product ratio is then calculated as follows:

$$\text{Dilution (X)} = \frac{\text{Amount of Mixed Solution} - \text{Amount of Concentrate Drawn}}{\text{Amount of Concentrate Drawn}}$$

Dilution ratio, then, equals X parts water to one part concentrate (X:1). If the test does not yield the desired ratio, choose a different tip and repeat the test. Alternative methods to this test are 1) pH (using litmus paper), and 2) titration. Contact your concentrate supplier for further information on these alternative methods and the materials required to perform them.

PROBLEM SOLVING:

Problem	Cause	Remedy
1. No discharge	a. No water b. Defective magnetic valve assembly c. Excessive water pressure	a. Open water inlet valve b. Replace assembly c. Install regulator if pressure exceeds 85 PSI static
2. No concentrate draw	a. Clogged foot valve strainer b. Metering tip or eductor clogged c. Low water pressure d. Discharge tube or flooding ring not in place	a. Clean or replace b. Clean or replace* c. Minimum 25 PSI flowing required d. Reposition tube, or replace tube if flooding ring misplaced
3. Failure of unit to turn off	a. Valve parts dirty or defective b. Magnet not returning c. Clogged valve orifice d. Diaphragm stretched	a. Clean or replace* b. Free magnet/replace spring c. Clean or replace* d. Replace
4. Backflow into concentrate	a. Mixed solution being siphoned back into concentrate container	a. Replace foot valve Drill antisiphon hole in discharge hose (see installation instructions step #2). Add or replace siphon breaker

* In hard water areas, scale may form at the discharge end of the eductor or valve orifice. Be sure the pilot holes in the diaphragm are clear. Scale may be removed by soaking the scaled part in a descaling or deliming solution. Alternately, the descaling solution may be educted through the unit, allowed to sit, then flushed prior to use of the unit with concentrate. Be sure descaling solution does not discharge into primary holding tank.

HydroMinder Models 561 & 562 Parts Diagram and List

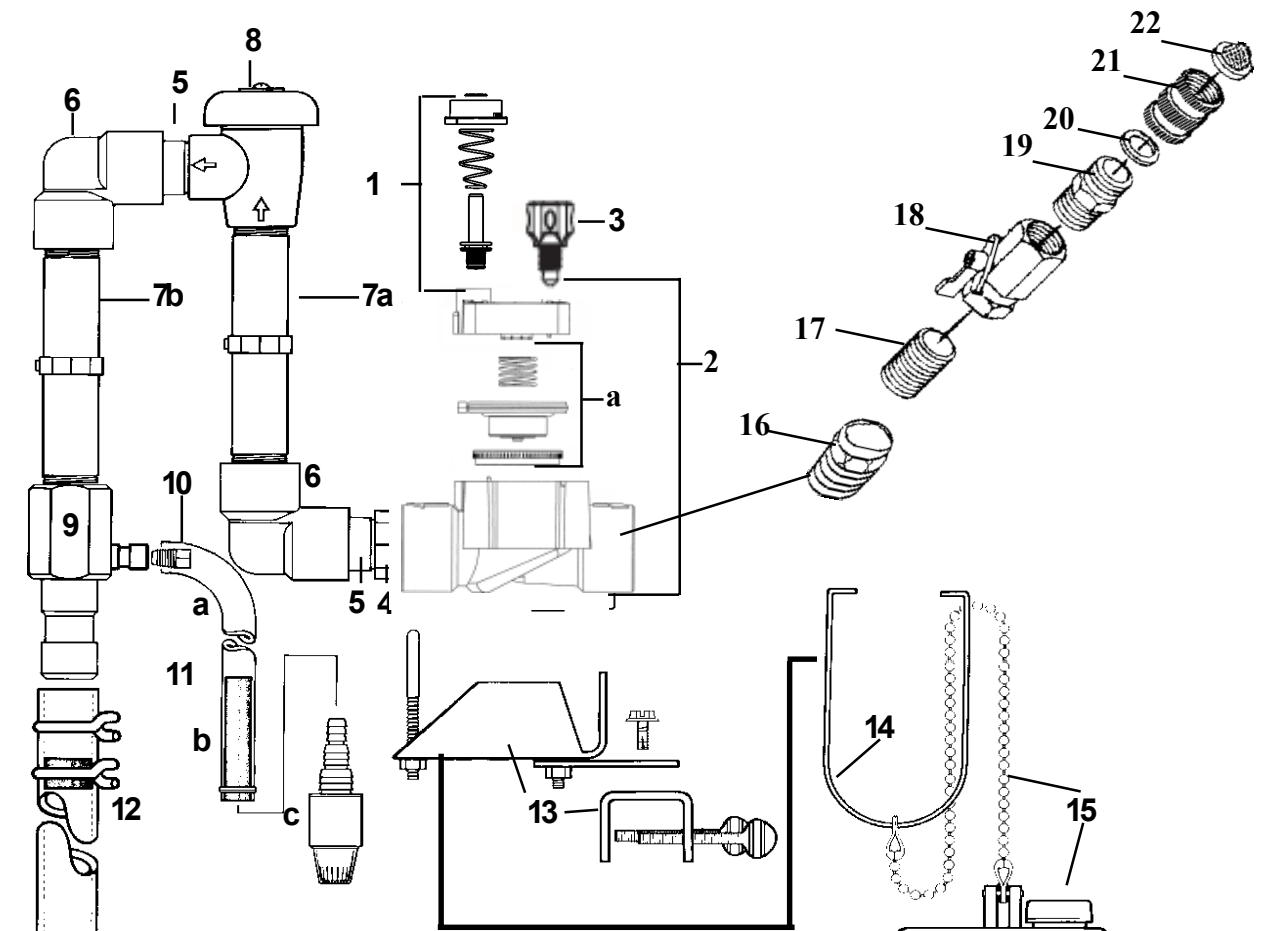

Key	PartNo.	Description
1	10091907	actuator assembly
2	10091661	valve
a	10091906	diaphragm replacement kit
3	10091902	bleed screw
4	560180	bushing (3/4 x 1)
5	560190	nipple (3/4 x 2 PVC)
6	560210	elbow (3/4 PVC)
7 a	560220	nipple (3/4 x 6 PVC) 562 only
b	560220	nipple (3/4 x 6 PVC)
8	507600	siphon breaker 562 only
9	5083-K	eductor (16 GPM)
10	690015	metering tip (kit)
11	5058-9	suction tube assembly
a	505809	1/2" x 9' tubing
b	250006	weight
c	10076301	foot valve, Viton

Key	PartNo.	Description
12	560330	discharge tube assembly
13	10091668	bracket assembly
14	560130	magnetyoke
15	5043-A	float & chain assembly
16	560180	bushing
17	508800	nipple
18	508700	ball valve
19	611500	adapter
20	270700	washer
21	607900	hose swivel
22	238100	strainer washer