

Troubleshooting Chart:

Problem	Cause	Remedy
1. No concentrate draw	a. Clogged check valve b. Metering tip or eductor clogged c. Low water pressure d. Clogged foot strainer e. Concentrate container empty f. Check valve not screwed into eductor tightly	a. Clean or replace b. Clean (descale) or replace* c. Minimum 25 PSI required to operate unit d. Clean or replace e. Replace with full container f. Tighten
2. Excess concentrate draw	a. Metering tip not in place	a. Push tip firmly into eductor suction stub
3. Low or no water flow	a. Water inlet screen clogged b. Supply source inadequate c. Scale build-up on eductor or fittings d. Backflow preventer screen clogged	a. Clean inlet screen (also check screen inside backflow preventer) b. 5 GPM inlet flow required. Move unit to adequate source or replumb incoming line. c. Clean or replace* d. Check backflow preventer screen for debris and clean twice yearly
4. Backflow into concentrate	a. Eductor check valve inoperable	a. Replace check valve
5. Discharge from backflow preventer vent	a. Backflow preventer check valve dirty or defective b. Water hammer condition in supply system (cause of "spitting") c. Negative pressure in supply line causing reverse flow	a. Clean or replace backflow preventer (Kit #105) b. Install water hammer shock arresters or water pressure reducing valves c. This is the proper operation of this component. Cause of negative pressure must be corrected.
* In hard water areas, scale may form at the discharge of the eductor or other fittings. This scale may be removed by soaking in a descaling (deliming) solution or by running the descaling solution through the system. If descaling solution is educted through unit, let it run through unit for a minute, then flush the system by educting clear water through it. Then return suction tube strainer to concentrate.		

FoamMaster Model 890 Compressed Air Power Cleaning System

Package Contains:

- | | | |
|------------------------|---------------------------|---|
| 1. FoamMaster unit. | 4. Ceramic weight. | 7. Instruction sheet. |
| 2. Metering tip kit. | 5. Foot strainer. | 8. Discharge shut off/nozzle head assy. |
| 3. Suction tube, 6 ft. | 6. Mounting hardware kit. | 9. Discharge hose, 25'. |

THANK YOU FOR YOUR INTEREST IN OUR PRODUCTS

Hydro Systems manufactures quality chemical proportioners.

Please use this equipment carefully and observe all warnings and cautions.

***** **NOTE** *****

- | | |
|---------------|---|
| WEAR | protective clothing and eyewear when dispensing chemicals or other materials. |
| ALWAYS | observe safety and handling instructions of the chemical manufacturers. |
| ALWAYS | direct discharge away from you or other persons or into approved containers. |
| ALWAYS | dispense cleaners and chemicals in accordance with manufacturer's instructions. Exercise CAUTION when maintaining your equipment. |
| KEEP | equipment clean to maintain proper operation. |
| WEAR | protective clothing and eyewear when working in the vicinity of all chemicals, filling or emptying equipment or changing metering tips. |
| ALWAYS | re-assemble equipment according to instruction procedures. Be sure all components are firmly screwed or latched into position. |
| ATTACH | only to tap water outlets (85 PSI maximum). |

Through proper care and maintenance, this equipment will serve your toughest cleaning jobs.

Installation:

If unfamiliar with component names, see parts diagram on page 3.

- Attach the unit to a wall or other structure, using anchors and screws provided.
- Select a metering tip (#18) using the chart at right as a guideline and push it firmly into the check valve (#17) hose barb. Secure the strainer to the 6' suction tube and slide the ceramic weight over (#21) connection. Connect tube to end of check valve. The strainer end of the suction tube can be dropped directly into the concentrate container.
- Connect the FoamMaster to the water supply through an adjustable pressure regulator to allow best operation and foam quality. Connect the regulated water supply to the (#39-40) water inlet at the bottom of the FoamMaster.
- Connect a compressed air line to the quick fitting supplied at the top left side of the FoamMaster. (#1)
- Connect the discharge hose to the manifold outlet at the top right of the unit. (#11)

Operation:

- The FoamMaster has shut-off valves in the water and air supply lines, an air pressure gauge and a rinsing by-pass valve near the center of the unit. A large hose end shut-off valve and nozzle assembly (#41) is supplied to be used at the end of the discharge hose. The larger nozzle opening is typically to be used in the foaming operation, the smaller for the rinse. These controls all play a part in the proper operation of the FoamMaster.

Continued, next page . . .

APPROXIMATE DILUTIONS @ 40 PSI FOR WATER-THIN PRODUCTS (1.0 CP)

Tip Color	Orifice Size	Std. Drill Number	Ratio
No Tip	.187	(3/16)	5.5:1
Gray	.128	(30)	5.5:1
Black	.098	(40)	5.5:1
Beige	.070	(50)	6.5:1
Red	.052	(55)	10:1
White	.043	(57)	14:1
Blue	.040	(60)	17:1
Tan	.035	(65)	20:1
Green	.028	(70)	34:1
Orange	.025	(72)	41:1
Brown	.023	(74)	52:1
Yellow	.020	(76)	68:1
Aqua	.018	(77)	77:1
Purple	.014	(79)	134:1
Pink	.010	(87)	241:1



Hydro Systems • 3798 Round Botom Road • Cincinnati, OH 45244 USA
Phone: (513) 271-8800 • Fax: (513) 271-0160

Operation (continued.):

2. Begin by opening the compressed air supply valve and adjust the air regulator (#3) so that the air pressure gauge reads approximately 40 PSI with air, water and product flowing. Water supply should be regulated to approximately 45 PSI. Now adjust air and water to produce desired foam quality.
3. **Foam character adjustment:**
The nature of the foam can be varied by changing the amount of concentrate drawn, water pressure and/or air pressure. Different products will perform differently in the FoamMaster due to viscosity, foaming nature, etc.
 - a) A larger diameter metering tip increases concentration, creating a thicker, richer foam. Larger diameter also helps reduce bucking of discharge.
 - b) More air pressure tends to deliver thicker, drier foam and will increase throw of foam. However, it can destroy foam quality if concentration of the product is too low.
 - c) Lower water pressure tends to create drier foam.
4. **Rinsing:**
Rinsing is accomplished by turning off the air supply and open the rinse by-pass valve of the unit. To change the nozzle position, pull back on the quick disconnect below the nozzle, switching to the smaller opening of the nozzle head. This stops the draw of concentrate and offers full water flow for rinsing.

Measurement of Concentration:

Final dilution is related to the size of the orifice in the metering tip used and product viscosity. The ratio is also affected by water pressure, temperature and flow rate. You can determine the dispensed water-to-product ratio for any metering tip size and product viscosity. All that is required is to operate the primed dispenser for a minute or so and note two things; the amount of dispensed water-to-product solution and the amount of concentrate used in preparation of the solution dispensed. The water-to-product ratio is then calculated as follows:

$$\text{Dilution (X)} = \frac{\text{Amount of Mixed Solution Dispensed} - \text{Amount of Concentrate Drawn}}{\text{Amount of Concentrate Drawn}}$$

Dilution ratio, then, equals X parts water to one part concentrate (X:1). If the test does not yield the desired ratio, choose a different tip and repeat the test. Alternative methods to this test are 1) pH (using litmus paper), and 2) titration. Contact your concentrate supplier for further information on these alternative methods and the materials required to perform them.

Parts List:

KEY	PART #	DESCRIPTION	KEY	PART #	DESCRIPTION
1	419342	1/4" MPT Air Coupler	23	506502	Swivel Stem
2	234300	Brass Hex Nipple 1/4 MP	24	10045800	Adapter, Mgh x 1/2" fnpt
3	503400	Air Regulator	25	2330.R	Bushing
4	10088312	Air Gauge, WIKA 111.10	26	419301	Nozzle, H1
5	10088315	Screw PH pan HD	27	620100	Tee, 1/4 & Street
6	10005803	Nut, 1/4 - 20	28	502000	Ball Valve
7	10041701	Conduit Hanger 1/2 - 3/4	29	10084021	Acorn Nut, MG x 1
8	419306	Vinyl tubing 3/4"	30	10084020	Ball Valve - KITZ
9	10088330	Check Valve	31	10075156	Street Elbow 3/8 (cast)
10	10088305	Keeper, 890	32	326300	Street Elbow
11	10088310	Adapter, Hose End, 890	33	604400	Brass Nipple 3/8"x2 1/2"
12	10048201	Tee with rib	34	133000	Tee, Branch 3/8"
13	270702	Washer	35	10084025	Screw, 1/4 - 20 by 1/2"
14	10059204	Elbow-H' Chem III	36	10067800	Nipple
15	607900	Swivel, Hose, Double 3/4	37	607600	Ball Valve
16	10067600	Eductor orange	38	276800	Swivel Stem, short
17	10069263	Check Valve Viton 3/8"	39	238100	Strainer, Washer
18		Metering Tip	40	10035311	V3 Check Valve
19	10044300	Tubing, 3/8" x 6'	41	10088356	Discharge Ball Valve Nozzle Head Assembly
20	509900	Ceramic Weight			
21	90064415	Foot Strainer			
22	276701	Swivel Nut			
		NOT SHOWN:			
		10088300			Cover
		10088311			Grommet, Ga.
		133			Hose, 3/4" x 25'

FoamMaster Model 890 Parts Diagram/List

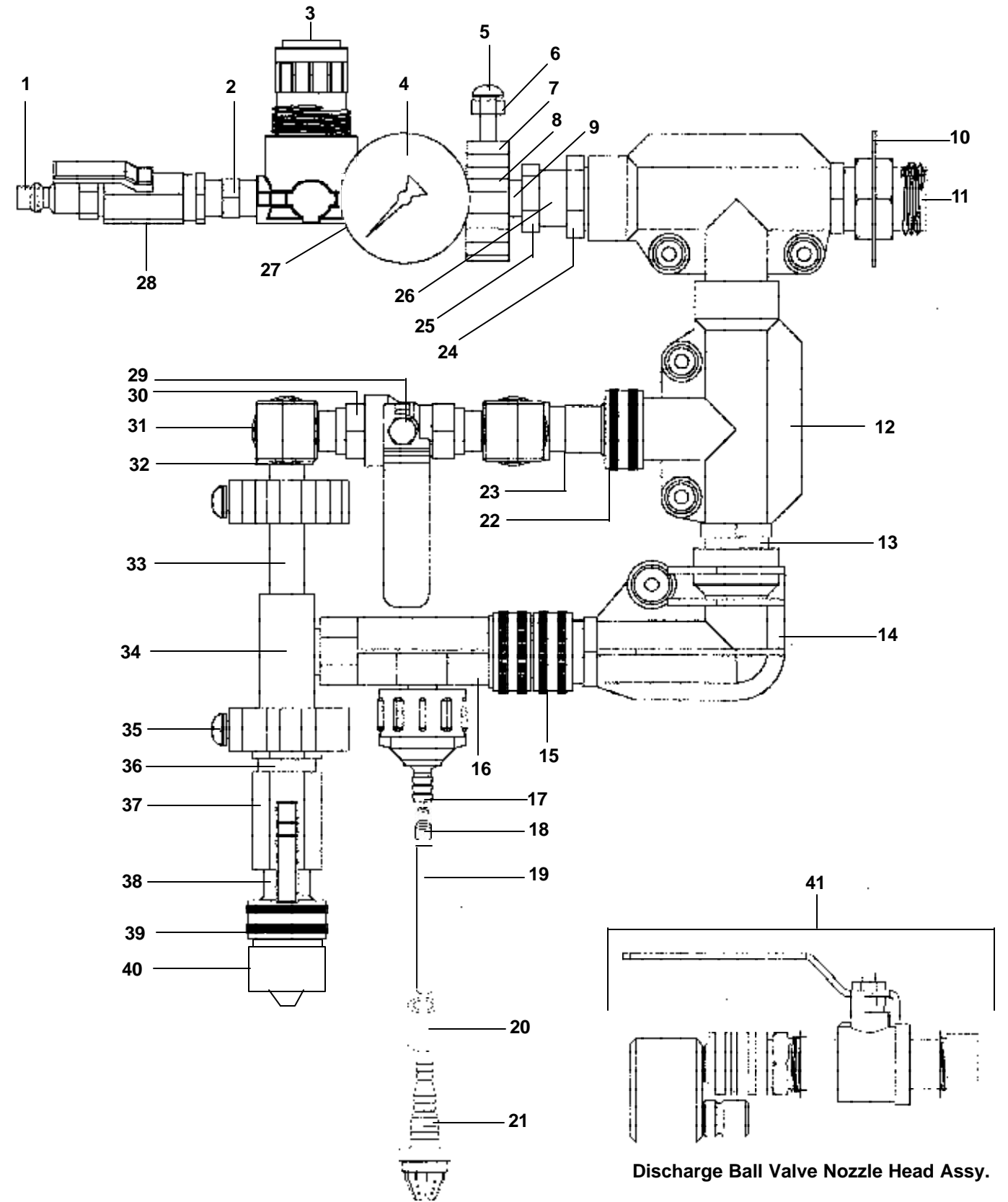

Discharge Ball Valve Nozzle Head Assy.