



### Metering Tip Selection:

The final concentration of the dispensed solution is related to both the size of the metering tip opening and the viscosity of the liquid being siphoned. For water-thin products, the chart at right can be used as a guideline. If product is noticeably thicker than water, consult the Measurement of Concentration Procedure below to achieve your desired water-to-product ratio. Because dilution can vary with water temperature and pressure, actual dilution achieved can only be ascertained by using the Measurement of Concentration Procedure. The clear, undrilled tip is provided to permit drilling to size not listed should you need a dilution ratio that falls between standard tip sizes.

**NOTE:** Refer to parts diagram if unfamiliar with names of system components.

### Measurement of Concentration:

You can determine the dispensed water-to-product ratio for any metering tip size and product viscosity. All that is required is to operate the primed dispenser for a minute or so and note two things: the amount of dispensed solution, and the amount of concentrate used in preparation of the solution dispensed. The water-to-product ratio is then calculated as follows:

APPROXIMATE DILUTIONS AT 40 PSI FOR WATER-THIN PRODUCTS (1.0 CP)				
Tip Color	Orifice Size	Std. Drill Number	Ratio (per Eductor Flow)	
			1 GPM	4 GPM
No Tip	.187	(3/16)	3:1	3.5:1
Grey	.128	(30)	3:1	4:1
Black	.098	(40)	3:1	4:1
Beige	.070	(50)	4:1	8:1
Red	.052	(55)	5:1	14:1
White	.043	(57)	7:1	20:1
Blue	.040	(60)	8:1	24:1
Tan	.035	(65)	10:1	30:1
Green	.028	(70)	16:1	45:1
Orange	.025	(72)	20:1	56:1
Brown	.023	(74)	24:1	64:1
Yellow	.020	(76)	32:1	90:1
Aqua	.018	(77)	38:1	128:1
Purple	.014	(79)	64:1	180:1
Pink	.010	(87)	128:1	350:1

$$\text{Dilution Ratio (X:1)} \text{ where } X = \frac{\text{Amount of Mixed Solution} - \text{Amount of Concentrate Drawn}}{\text{Amount of Concentrate Drawn}}$$

Dilution Ratio, then, equals X parts water to one part concentrate (X:1). If the test does not yield the desired ratio, choose a different tip and repeat the test. Alternative methods to this test are 1) pH (using litmus paper), and 2) titration. Contact your concentrate supplier for further information on these alternative methods and the materials required to perform them.

### TaskMizer Parts Diagram List:

Key	Part No.	Description
1	10079003	Magnet Cover w/ chain slot
2	10079000	Magnet
3	10079010	Spring, Magnet return
4	90074612	Ball chain w/ sleeves
5	10075980	Valve parts kit d. diaphragm e. armature f. spring g. valve bonnet
6	10075925	Pipe plug, 3/8 npt x 2.54
7a	10088830	1GPM E-Gap Eductor
b	10088840	4 GPM E-Gap Eductor
8	10088852	Discharge tube assm.
9	10080957	Selector Valve Kit (short) a. support clip b. suction stub c. o-ring d. select valve assembly
10a	690014	Metering tip kit
b	690001	Clear metering tips
11	10075156	Street elbow, 3/8 npt
12	10082801	Swivel stem
13	10082830	Swivel collar
14	238100	Strainer washer
15	10084485	Discharge tube assembly 6'
16	10080730	Hose hook, dark grey
17	10080955	Select valve kit (long) a. support clip b. suction stub c. o-ring d. select valve assembly
18	500821	Tubing, 1/4" x 21'
	500814	Tubing, 1/4" x 14'
19	10089401	Check valve
20	10068721	Y hosebarb, 1/4"
21	509900	Weight
22	609600	Foot strainer
23	10068835	Locking button kit
24	10082730	Locking button assembly

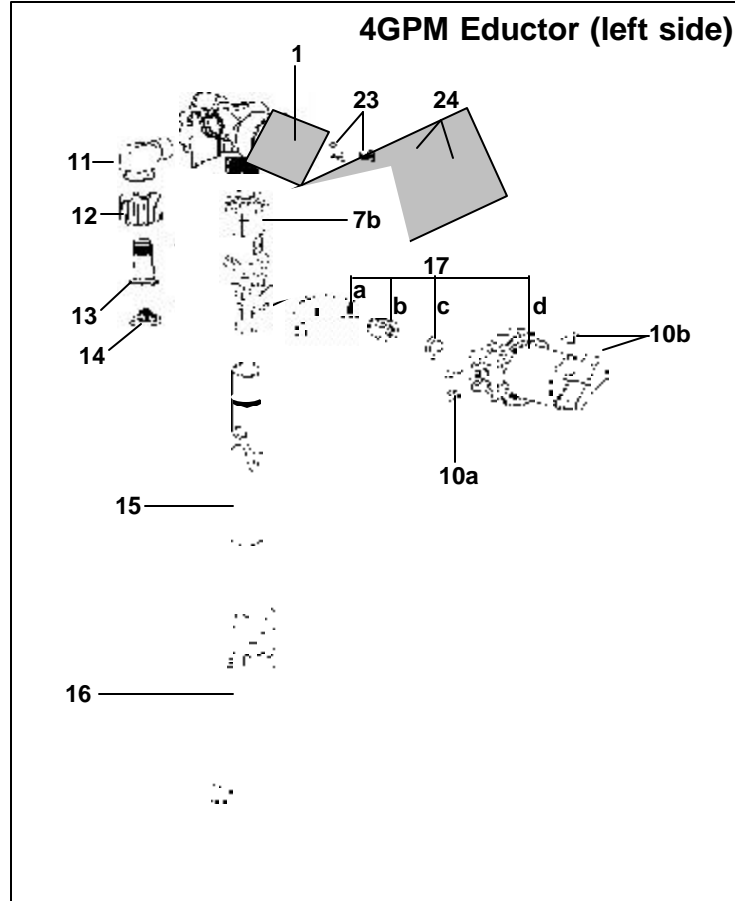

### TaskMizer Parts Diagram Cont.

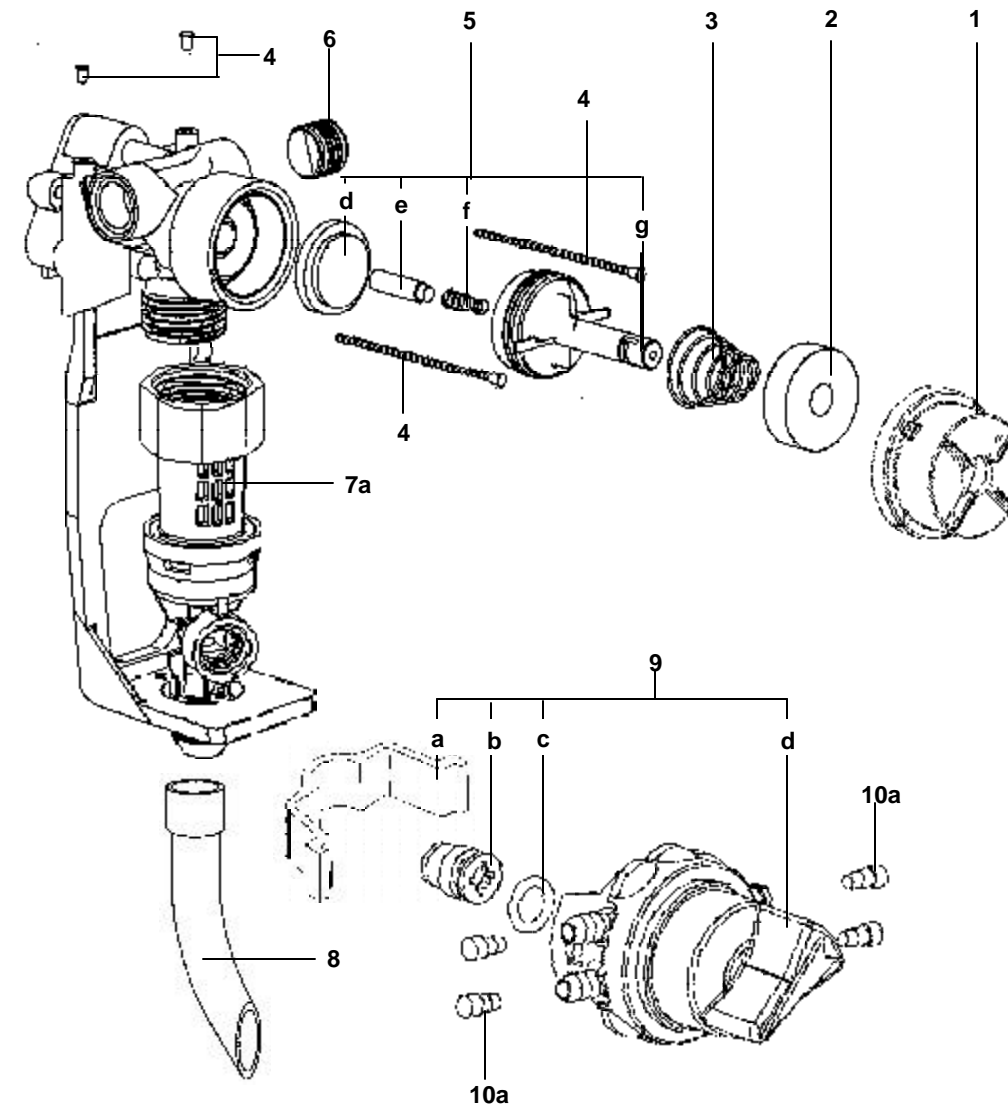

### Dual Dilution Pickup Line Assembly: Single Product

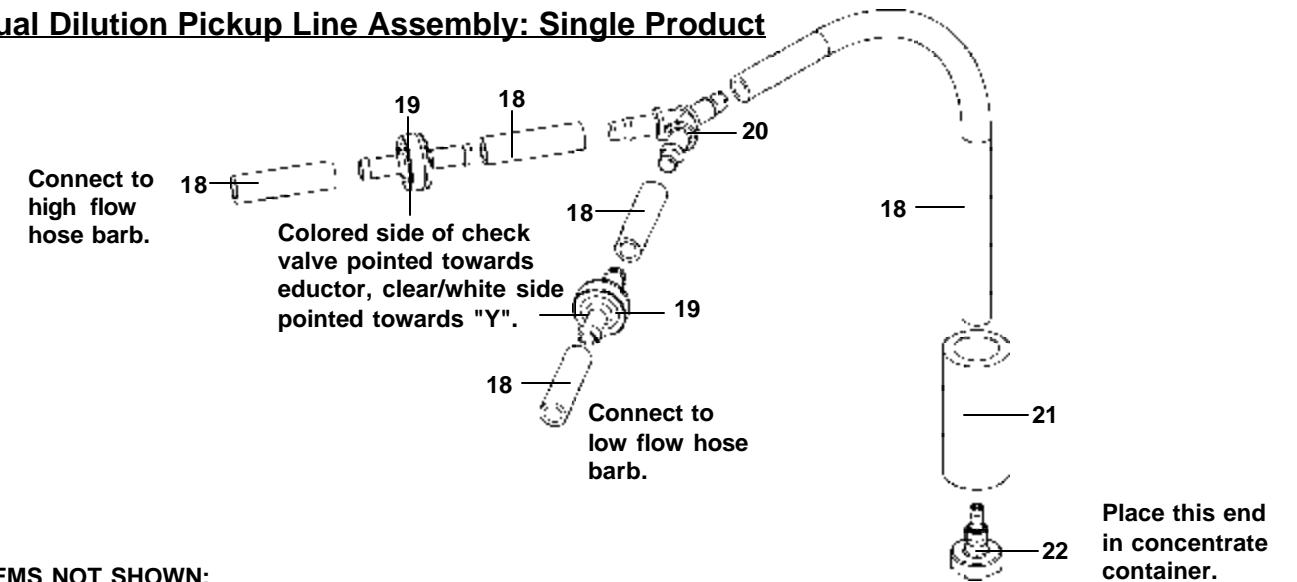

### ITEMS NOT SHOWN:

- Cabinet front
- Cabinet back
- 10088609 Mounting bracket
- 10088608 Drip tray
- 641751 Security screws (for cabinet sides)