



SinkMaster Model 8831 with E-Gap Eductors

Package Contains:

- | | |
|--------------------------------|-------------------------|
| 1. Proportioner unit. | 4. Discharge tubes. |
| 2. Suction tubing: 1/4" x 14'. | 5. Metering tip kit. |
| 3. Foot valves and weights. | 6. Mounting anchor kit. |

THANK YOU FOR YOUR INTEREST IN OUR PRODUCTS

Hydro Systems manufactures quality chemical proportioning equipment. Please use this equipment carefully and observe all warnings and cautions.

***** NOTE *****

WEAR	protective clothing and eyewear when dispensing chemicals or other materials.
ALWAYS	observe safety and handling instructions of the chemical manufacturers.
ALWAYS	direct discharge away from you or other persons or into approved containers.
ALWAYS	dispense cleaners and chemicals in accordance with manufacturer's instructions. Exercise CAUTION when maintaining your equipment.
KEEP	equipment clean to maintain proper operation.
WEAR	protective clothing and eyewear when working in the vicinity of all chemicals, filling or emptying equipment or changing metering tips.
ALWAYS	re-assemble equipment according to instruction procedures. Be sure all components are firmly screwed or latched into position.
ATTACH	only to tap water outlets (85 PSI maximum).
NOTE	If the unit is used to fill a sink or the discharge hose can be placed into a sink, the unit must be mounted so that the bottom of the cabinet is above the overflow rim of the sink.

Installation and Operation:

- Hold unit up to wall and drill holes for the wall anchors with a 9/32" drill. Install mounting anchors, and then install screws into top two anchors. Slide key holes at top of dispenser over screw heads. Install bottom two screws through holes in cabinet. Tighten all screws. Do not mount more than 6 ft. (1.8 m) above bottom of concentrate container, nor below the highest concentrate level (never mount your concentrate higher than the dispenser). Turn ball valves so they are in a horizontal position (pointing left and right).
- Select metering tips (see next section) and insert a tip into each hose barb on the eductor bodies.
- Suction tubes should reach from hose barbs on eductors to bottoms of concentrate containers. Cut tube supplied to lengths required. (There is enough tube for 7 feet of tube per eductor.) Slide a weight over one end of each suction tube and slide a foot valve into the same ends of the tubes.
- Slip open ends of suction tubes over the hose barbs/metering tips on the eductors (one at each side).
- A long (4ft.) discharge tube is used with 4 GPM (yellow) eductors. Do not remove flooding rings from inside the tubes. Slide end of tube with flooding ring over discharge outlet.
- Install outer discharge tubes over inner discharge tubes. Put the ends of the tubes into the appropriate sink compartments.
- Place foot valve ends of supply tubes into concentrate containers. REMEMBER TO CHECK FOOT VALVE STRAINER PERIODICALLY FOR CLOGGING: CLEAN IF NECESSARY.
- Connect water supply hose of at least 1/2" ID to water inlet swivel. (Minimum 25 PSI pressure, with water running, is required for proper operation.) Connect other end of hose to water supply. Turn water supply on.
- Purge air from the system by opening the ball valves briefly. (Ball valves will be in vertical position -- pointing up and down -- when open.) There may be some water discharge from the eductor vents until the air is purged.
- Open one ball valve to start flow of desired water/concentrate solution, and run unit until supply tube is primed (filled). Repeat priming operation for other ball valve. Then, open ball valves when dispensing is desired. Close ball valves to stop flow of solution.

Metering Tip Selection:

The final concentration of the dispensed liquid is related to both the size of the metering tip opening and the viscosity of the liquid being siphoned. If product viscosity is noticeably greater than that of water, consult the procedure for Measurement of Concentration on the next page to achieve your desired water-to-product ratio. For water-thin products, use the chart on the next page as a **guideline**. Because such factors as inlet water pressure and temperature can affect dilution ratios, the figures listed on the chart are only approximate. Test the actual dilution you are achieving using the Measurement of Concentration procedure for best results. Use the undrilled, clear tip for drilling a size not listed.



Measurement of Concentration:

You can determine the dispensed water-to-product ratio for any metering tip size and product viscosity. All that is required is to operate the primed dispenser for a minute or so and note two things: the amount of dispensed solution, and the amount of concentrate used in preparation of the solution dispensed. The water-to-product ratio is then calculated as follows:

Dilution Ratio (X:1) where

$$X = \frac{\text{Amount of Mixed Solution} - \text{Amount of Concentrate Drawn}}{\text{Amount of Concentrate Drawn}}$$

Dilution Ratio, then, equals X parts water to one part concentrate (X:1). If the test does not yield the desired ratio, choose a different tip and repeat the test. Alternative methods to this test are 1) pH (using litmus paper), and 2) titration. Contact your concentrate supplier for further information on these alternative methods and the materials required to perform them.

APPROXIMATE DILUTIONS AT 40 PSI FOR WATER-THIN PRODUCTS (1.0 CP)			
Tip Color	Orifice Size	(Std. Drill Number)	Ratio
No Tip	.187	(3/16)	3.5:1
Gray	.128	(30)	4:1
Black	.098	(40)	4:1
Beige	.070	(50)	8:1
Red	.052	(55)	14:1
White	.043	(57)	20:1
Blue	.040	(60)	24:1
Tan	.035	(65)	30:1
Green	.028	(70)	45:1
Orange	.025	(72)	56:1
Brown	.023	(74)	64:1
Yellow	.020	(76)	90:1
Aqua	.018	(77)	128:1
Purple	.014	(79)	180:1
Pink	.010	(87)	350:1
Lt. Purple	.009	(89)	460:1

TROUBLESHOOTING CHART:

Problem	Cause	Solution
1. No discharge	a. No water	a. Turn on water supply
2. No concentrate draw	a. Clogged foot valve	a. Clean or replace
	b. Metering tip or eductor has scale build-up	b. Clean (descale) or replace
	c. Low water pressure	c. Minimum 25 PSI (with water running) required to operate unit properly
	d. Discharge tube and/or flooding ring not in place	d. Push tube firmly onto eductor discharge hose barb, or replace tube if it doesn't have a flooding ring
	e. Concentrate container empty	e. Replace with full container
	f. Inlet hose barb not screwed into eductor tightly	f. Tighten, but do not overtighten
3. Excess concentrate draw	a. Metering tip not in place	a. Press correct tip firmly into barb on eductor

NOTE: In hard water areas, scale may form inside the discharge end of the eductor, as well as in other areas of the unit that are exposed to water. This scale may be removed by soaking the eductor in a descaling solution (deliming solution). To remove an eductor located in the cabinet, unthread it. Alternatively, a scaled eductor can be cleaned (or kept from scaling) by drawing the descaling solution through the unit. Operate the unit with the suction tube in the descaling solution. Operate the unit until solution is drawn consistently, then flush the unit by drawing clear water through it for a minute. Replace concentrate container and put suction tube into concentrate.

SinkMaster Parts Diagram/List

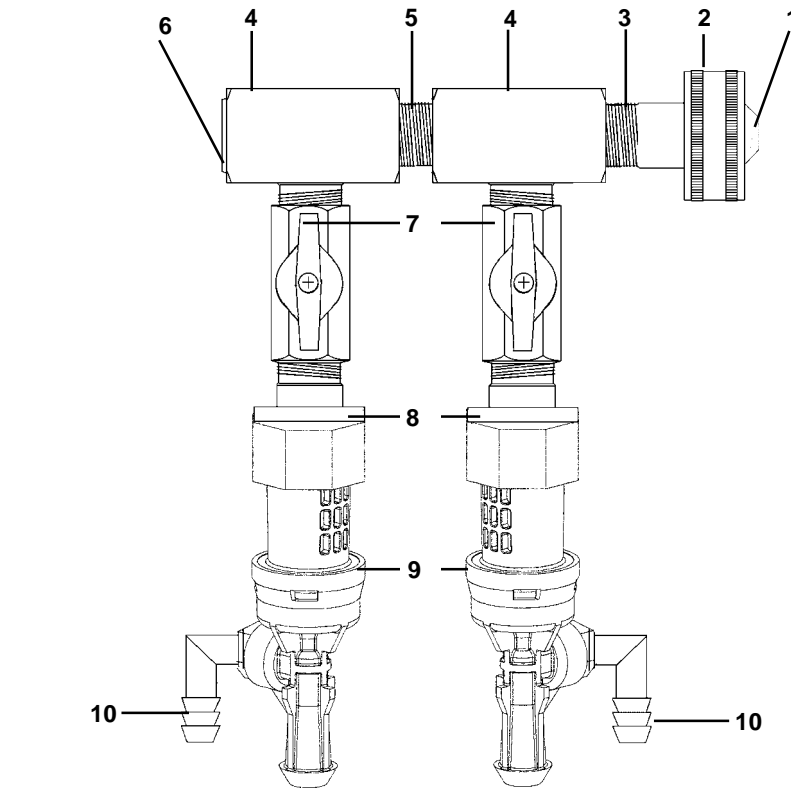

Key	Part No.	Description
1	238100	Strainer washer
2	506502	Swivel nut
3	276800	Swivel stem
4	133000	Branch tee
5	10027700	3/8" nipple
6	10075925	Pipe plug
7	10080320	Ball valve
8	10064652	3/8" x MGH fitting, sealed
9	291	3.5 GPM E-Gap Eductor Assy.
10	10077500	90° Angle hose barb
11	10027209	Metering tip (kit)
12	500814	Tubing, 1/4" x 14'
13	509900	Weight
14	10089410	Foot valve, Viton
15	90048495	Discharge tube assembly

NOT SHOWN:
10080301 Bracket/cover

