

HydroMinder Model 564: Parts Diagram and List

Key	Part No.	Description
1	10091907	actuator assembly
2	10091661	valve
a.	10091906	diaphragm replacement kit
3	10091902	bleed screw
4	560180	bushing (3/4 x 1)
5	560230	nipple (3/4 x 4 PVC)
6	560210	elbow (3/4 PVC)
7	560190	nipple (3/4 x 2)
8	560700	eductor (25 GPM)
9	690015	metering tip (kit)
10	5058-9A	suction tube assembly
a	505809	1/2" x 9' tubing
b	250006	weight
c	10076301	foot valve, Viton
11	560330	discharge tube assembly
12	10091668	bracket assembly
13	560130	magnet yoke
14	5043-A	float & chain assembly

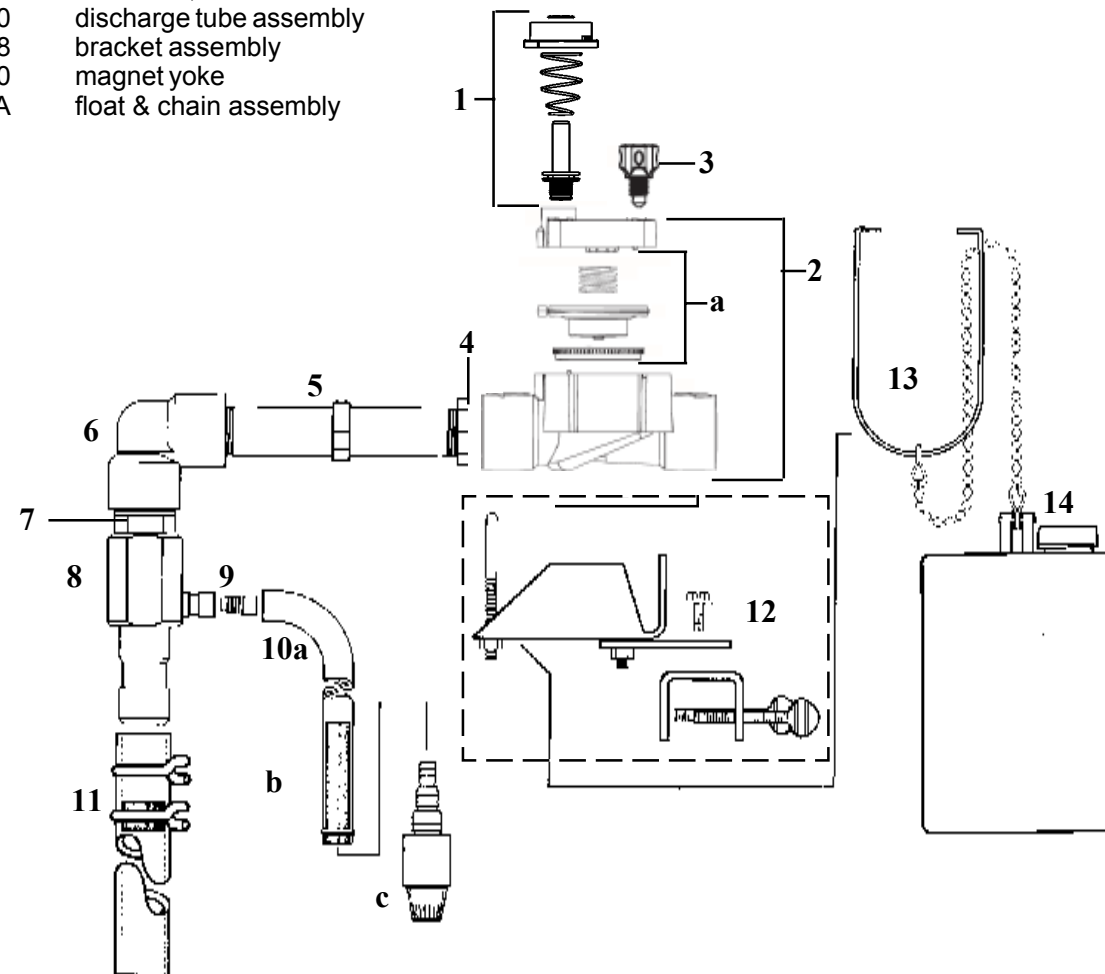

HydroMinder Models 563 & 564

PACKAGE CONTAINS:

1. Proportioner
2. Bracket for mounting
3. Float with chain
4. Supply tube with foot valve - 9 ft.
5. Discharge tube assembly - 2 ft.
6. Metering tip kit
7. Product information sheet

THANK YOU FOR CHOOSING OUR PRODUCTS

Hydro Systems manufactures quality chemical proportioners. Please use this equipment carefully and observe all warnings and cautions.

***** NOTE *****

WEAR	protective clothing and eyewear when working in the vicinity of all chemicals, filling or emptying equipment or changing metering tips.
ALWAYS	observe safety and handling instructions of the chemical manufacturers. direct discharge away from you or other persons or into approved containers. dispense cleaners and chemicals in accordance with manufacturer's instructions. exercise CAUTION when maintaining your equipment. REExercise CAUTION when maintaining your equipment.e-assemble equipment according to instruction procedures. Be sure all components are firmly screwed or latched into position.
CLEAN	equipment after each use in accordance with instruction sheet.
ATTACH	only to tap water outlets (85 PSI maximum).

INSTALLATION:

1. Select a metering tip (see next page) and install it into the suction stub on the eductor body.
2. Attach the end of the discharge tube with the clamp and flooding ring to the discharge barb on the eductor. On models without siphon breakers, you may want to drill a small hole (1/8" or 1/4" ID) in the discharge tube, above the highest solution level point and below the discharge end of the eductor. This will allow the discharge tube to drain after each cycle.
3. Mount the unit in a level position on the side of a reservoir. Reposition or remove bracket, if supplied, if necessary.
4. Insert foot valve end of suction tube into concentrate container. Cut tube to the length required so that tube goes just to the bottom of the concentrate container. (Level of concentrate in the container must be below the discharge point of the installed unit, or the HydroMinder will continue to siphon concentrate after it is turned off.)
5. Slide the open end of the suction tube over the suction stub.
6. Adjust chain length to position float at the desired highest level of solution. To prevent foaming, be certain that the point of discharge will be below the solution level at its lowest point. NOTE: The high volume HydroMinder Models 563 and 564 are designed to shut off slowly to help reduce water hammer. Be sure to take this into account when setting the high water level to prevent inadvertent tank overflow. Be sure float mechanism is not hampered by water turbulence caused by discharging solution. It may be necessary to baffle the float from the discharge in order for the unit to work properly.
7. Install minimum 1-inch water line to the HydroMinder valve. Minimum 25 PSI pressure of flowing water required at valve inlet. A supply shut-off valve should be installed ahead of the HydroMinder.

OPERATION:

Open the water supply valve. When the solution in the reservoir reaches the level set by the float, the valve will close. This will stop the water flow and siphoning of concentrate. When withdrawal of solution from the reservoir causes the level to drop, the valve will open and the reservoir will be refilled to the previous level. This cycle will be repeated automatically until the supply of concentrate is depleted. The water supply valve should be **fully closed** when changing metering tips, when reservoir is drained, or when the unit is not in use.



A DOVER COMPANY

Hydro Systems 3798 Round Bottom Road, Cincinnati, OH 45244 Phone: (513) 271-8800 Fax: (513) 271-0160

10091732
Rev. A 3/07

METERING TIP SELECTION:

Final dilution of concentrate is related to both the size of the metering tip opening and the viscosity of the liquid being siphoned. If product viscosity is noticeably greater than that of water, consult the procedure for Measurement of Concentration to achieve your desired water-to-product ratio. For water-thin products, consult the chart below. Two undrilled, clear tips are supplied for drilling sizes not listed.

Tip Color	Nominal Diameter	Dilution Ratio at 40 PSI, Water-thin Viscosity (1.0 CP)	For reference: Ounces/gallon	
No tip	Open connector	8:1	8:1 =	16 oz./gal.
Grey	.128	15:1		
Black	.098	25:1	16:1 =	8 oz./gal.
Beige	.070	45:1		
Red	.052	80:1	32:1 =	4 oz./gal.
White	.043	110:1		
Blue	.040	120:1	64:1 =	2 oz./gal.
Tan	.035	160:1		
Green	.02	240:1	128:1 =	1 oz./gal.
Orange	.025	330:1		
Brown	.023	390:1	256:1 =	½ oz./gal.
Yellow	.020	460:1		
Purple	.014	660:1		
Pink	.010	1200:1		

MEASUREMENT OF CONCENTRATION:

You can determine the dispensed water-to-product ratio for any metering tip size and product viscosity. All that is required is to operate the primed dispenser for a minute or so and note two things: the amount of dispensed water/product mixture, and the amount of concentrate used in preparation of the solution dispensed. The water-to-product ratio is then calculated as follows:

$$\text{Dilution (X)} = \frac{\text{Amount of Mixed Solution} - \text{Amount of Concentrate Drawn}}{\text{Amount of Concentrate Drawn}}$$

Dilution ratio, then, equals X parts water to one part concentrate (X:1). If the test does not yield the desired ratio, choose a different tip and repeat the test. Alternative methods to this test are 1) pH (using litmus paper), and 2) titration. Contact your concentrate supplier for further information on these alternative methods and the materials required to perform them.

PROBLEM SOLVING:

Problem	Cause	Remedy
1. No discharge	a. No water b. Defective magnetic valve assembly c. Excessive water pressure	a. Open water inlet valve b. Replace assembly c. Install regulator if pressure exceeds 85 PSI static
2. No concentrate draw	a. Clogged foot valve strainer b. Metering tip or eductor clogged c. Low water pressure d. Discharge tube or flooding ring not in place	a. Clean or replace b. Clean or replace* c. Minimum 25 PSI flowing required d. Reposition tube, or replace tube if flooding ring misplaced
3. Failure of unit to turn off	a. Valve parts dirty or defective b. Magnet not returning c. Clogged valve orifice d. Diaphragm stretched	a. Clean or replace* b. Free magnet/replace spring c. Clean or replace* d. Replace
4. Backflow into concentrate	a. Mixed solution being siphoned back into concentrate container	a. Replace foot valve or drill antisiphon hole in discharge hose (see installation instructions step #2). Add or replace siphon breaker

* In hard water areas, scale may form at the discharge end of the eductor or valve orifice. Be sure the pilot holes in the diaphragm are clear. Scale may be removed by soaking the scaled part in a descaling or deliming solution. Alternately, the descaling solution may be educted through the unit, allowed to sit, then flushed prior to use of the unit with concentrate. Be sure descaling solution does not discharge into primary holding tank.

HydroMinder Model 563: Parts Diagram and List

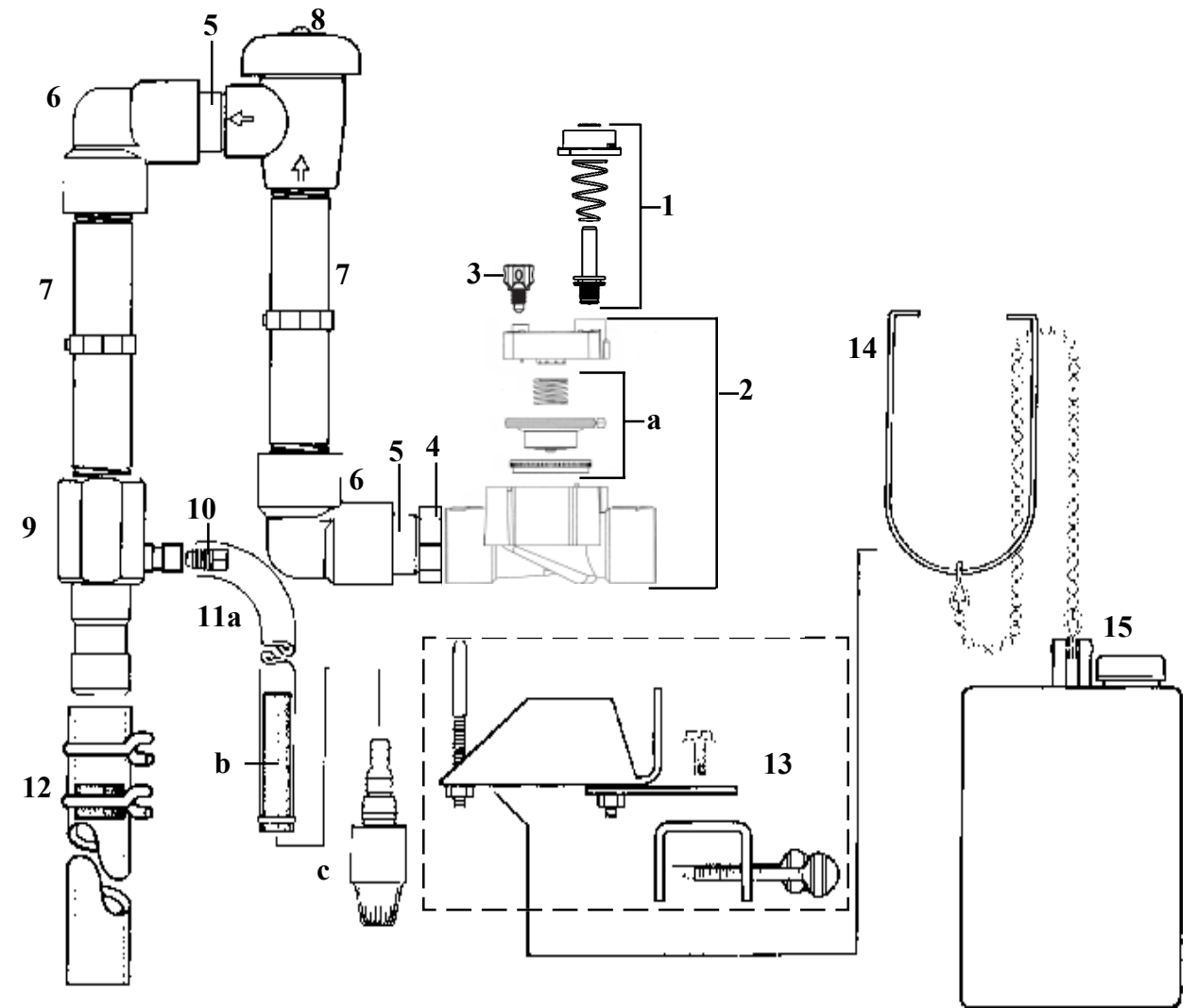

Key	Part No.	Description	Key	Part No.	Description
1	10091907	actuator assembly	9	560700	eductor (25 GPM)
2	10091661	valve	10	690015	metering tip (kit)
	a. 10091906	diaphragm replacement kit	11	5058-9A	suction tube assembly
3	10091902	bleed screw	a	505809	1/2" x 9' tubing
4	560180	bushing (3/4 x 1)	b	250006	weight
5	560190	nipple (3/4 x 2 PVC)	c	10076301	foot valve, Viton
6	560210	elbow (3/4 PVC)	12	560330	discharge tube assembly
7	560220	nipple (3/4 x 6 PVC)	13	10091668	bracket assembly
8	507600	siphon breaker	14	560130	magnet yoke
			15	5043-A	float & chain assembly