

# Hydro<sup>®</sup> ICS 8900

---



**Integrated Cleaning System**  
**Rechargeable Battery**

## THANK YOU FOR CHOOSING OUR PRODUCTS

Hydro Systems manufactures quality chemical proportioners. Please use this equipment carefully and observe all warnings and cautions.

### WEAR

protective clothing and eyewear when working in the vicinity of chemicals or other materials, when filling or emptying equipment or changing metering tips.

### ALWAYS

re-assemble equipment according to instruction procedures. Be sure all components are firmly screwed or latched into position.

direct discharge away from you or other persons or into approved containers.

exercise CAUTION. Dispense cleaners and chemicals in accordance with manufacturer's instructions.

observe safety and handling instructions of the chemical manufacturers.

### CLEAN

equipment after each use to maintain proper operation.

## Packing List

Unit with integral 12.5 gallon water reservoir

Battery & charger (installed)

Spray attachment w/ 2 nozzles (installed)

15 ft. discharge hose (installed)

(2) Bottle holders for 1 gal. rectangular bottles

(2) Bottle holders for 1 gal. round bottles (installed)

Metering tip kit

Instruction manual

(2) Chemical feed line assemblies (installed), include:

Tube

Weight

Strainer

Cap

Battery charger  
cord wrap

Control panel

Chemical feed-  
line assembly

Chemical bottle  
holder for 1 gal.  
round.

Water fill port

(access to water pick-up assembly,  
see Fig. A)

**Fig. A Water pick-up assembly**

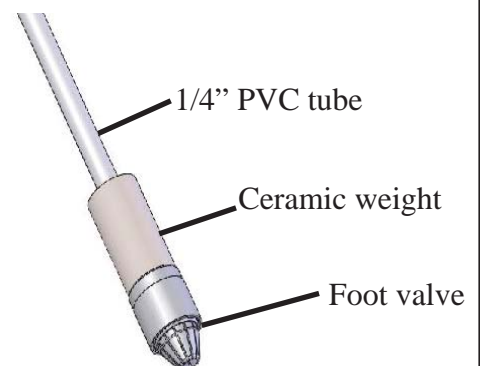

## **Overview:**

The ICS 8900 is a battery powered, portable, self-contained unit designed to make daily maintenance of your facility easier. This unit includes the following features:

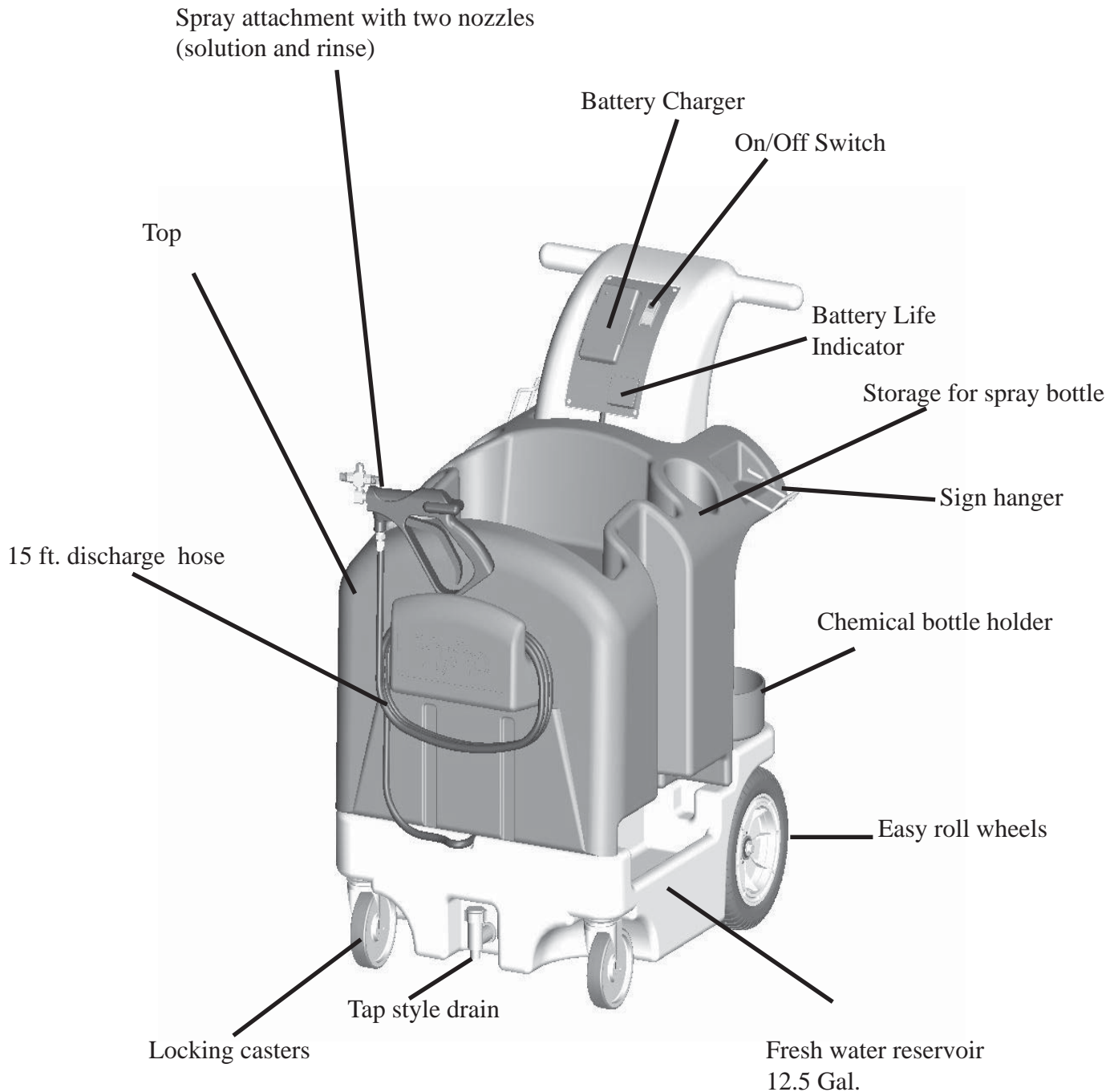

## Initial Set-up

1. Remove any items sitting on the cart top.
2. Remove cart top by lifting near the chemical bottles. See Fig. B.
3. Remove tubing from checkvalve/metering tip holder.
4. Push the selected metering tip into metering tip holder. See Fig. C.
5. Replace tubing.
6. Connect the red wire to the red terminal on the battery.
7. Replace top.

Fig. B

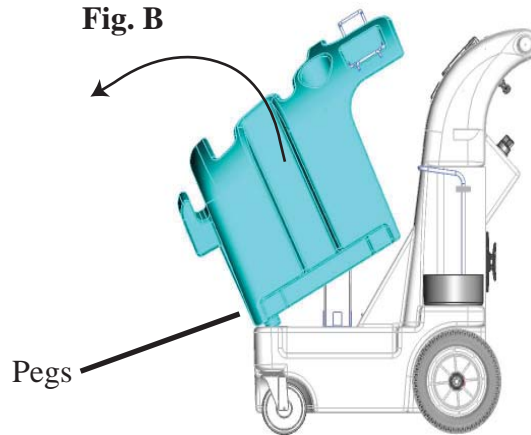
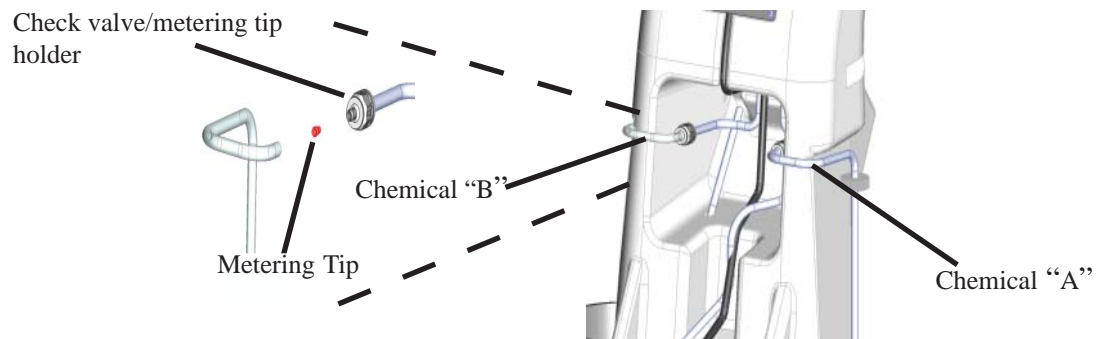

Fig. C



### Metering Tip Selection:

The final concentration of the dispensed solution is related to both the size of the metering tip opening, and the viscosity of the liquid being siphoned. For water-thin products, the chart can be used as a guideline. Because dilution can vary with water temperature and pressure, and if the product is noticeably thicker than water, dilution rates shown should be viewed as approximate.

Orifice Size	Tip Color	Average Dilution Ratio
	<b>no tip</b>	4:1
0.128	<b>grey</b>	4.25:1
0.098	<b>black</b>	4.5:1
0.070	<b>beige</b>	4.5:1
0.052	<b>red</b>	5:1
0.043	<b>white</b>	6:1
0.040	<b>blue</b>	7:1
0.035	<b>tan</b>	8:1
0.028	<b>green</b>	10:1
0.025	<b>orange</b>	12:1
0.023	<b>brown</b>	16:1
0.020	<b>yellow</b>	20:1
0.018	<b>aqua</b>	24:1
0.014	<b>purple</b>	32:1
0.010	<b>pink</b>	64:1

## Initial Setup (cont.)

8. The spray attachment is in the accessory box. Attach it to the discharge hose.
9. Remove the black cap from the water fill port (it rotates COUNTER CLOCKWISE to open). Fill the tank with cool, clear tap water. See Fig. D.
10. To connect the chemicals, remove the shipping cap and the seal on your chemical bottle and discard. Place the strainer and weight into chemical bottle and screw the chemical feed line cap on to bottle. See Fig. E.

## Prime the Unit

1. Set the nozzle on the spray attachment to "S". See Fig. F.
2. Set the chemical select valve to either of the products (lower two positions on select valve). See Fig. G.
4. Turn the power switch on. The pump should run for a short time, then stop. (The pump will run until the discharge pressure reaches the factory set point. The pump will then turn off until the trigger on the spray attachment is activated.)
5. Direct the spray nozzle into a drain or other container and pull the trigger.
6. Run until a steady spray pattern is established, without air in the water stream.
7. Release the trigger. The pump should stop almost immediately. If it does not, operate the unit longer as it is not fully primed.
8. Turn the selector to the other product and repeat.

**Fig. D**

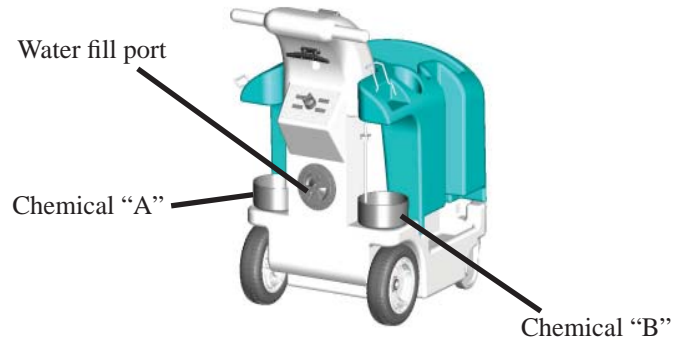

**Fig. E**

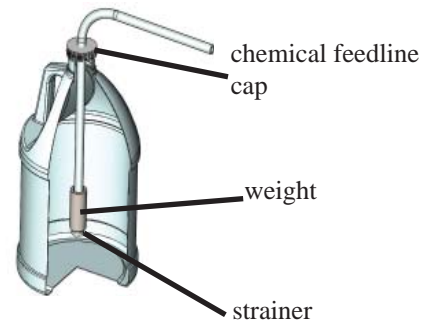

**Fig. F**

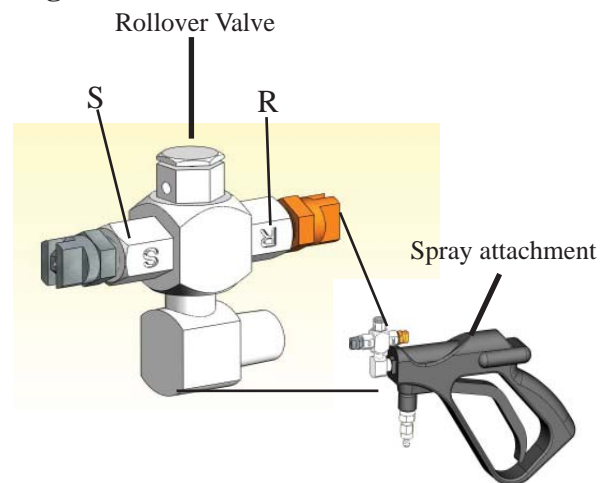

**Fig. G**

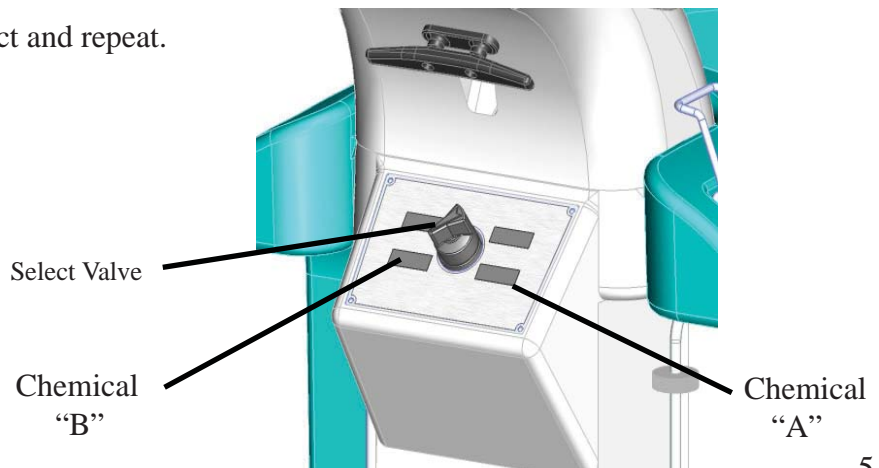

## **Normal Operation:**

1. The power switch is lighted when it is in the “ON” position.
2. The pump will run when the trigger on the spray attachment is pulled and stop when it is released.
3. The rollover valve on the outlet of the spray attachment selects between the two attached spray nozzles. “S” should be used when applying either product, “R” is used for rinsing. The rinse is a fine spray pattern, while the “S” is a pattern that is more coarse.
4. Run the unit approximately 10 seconds to flush prior chemical from hose.

**NOTE: To apply either chemical you must use nozzle “S” for proper dilution.**

## **Out of water/chemical indication:**

When the system runs out of either water or chemical, air will enter the water stream and it will become “rough.” The pump may also continue to run when the trigger is released. Turn off the power immediately, fill the water reservoir and/or replace the empty product container, and repeat the priming operation.

**CAUTION: Continuous cycling of the pump (continuous, rapid on/off cycles) indicates a problem with the unit. Have the unit serviced immediately.**

## **Maintenance:**

### **Daily:**

1. When finished using the pump for the day, run the pump two to four minutes with the select valve and nozzle in rinse position, to purge chemical from the unit. See Fig. G.
2. Set the nozzle to “S” (keep the select valve in the rinse position) and run for ten seconds.
3. Turn the unit off with the switch. Relieve the pressure in the discharge hose by pulling the trigger on the spray attachment after the switch has been turned off. A small amount of water will discharge.
4. Check the unit for any damage or leakage.
5. If the unit is going to be stored where it can freeze, drain the water reservoir and run the pump until there is no more water in the system. Allow the system to thaw before you start the pump.
6. Plug the unit into a 120 Volt outlet to recharge the battery. The indicator light on the charger will be red while the battery is charging, and green when the battery is fully charged. Leave the charger plugged in during long term storage to maintain the battery at peak capacity. Note: It is not necessary to fully discharge the battery before recharging.

**NOTE: Failure to follow this procedure after use will void the warranty on the pump.**

## **Troubleshooting:**

1. **The spray is weak or there is no spray.** The pump does not operate at full flow if there is air in the system. Air can enter the system from several sources:
  - a. Out of water - fill the water reservoir and prime the system.
  - b. Out of chemical - replace the chemical container and prime the system.
  - c. Foot valve is clogged - clean or replace the foot valve in the reservoir. To access the foot valve, remove fill port cap. Pull water pick-up assembly out through fill port. The foot valve is mounted on the end of the water pick-up assembly, and is designed to be removed without tools. See Fig. H.
  - d. Leak in one of the fittings. Remove the cart top and find the source of bubbles. Correct the leak.
  - e. Battery is low, check battery life indicator, if necessary, recharge.
2. **Pump pulses.** There is a pressure switch in the pump. If the pump is pulsing, this switch is cycling and the life of the pump will be greatly reduced. Have the pump serviced.
3. **Pump not running.**
  - a. Battery is dead, recharge.
  - b. Loose battery connection, check that both terminals are connected.

### **Note:**

- **The pump does not contain any field serviceable parts.** It should run for 800 to 1000 hours with no maintenance needed. If leaks occur in the pump, it needs to be replaced.

- **The pump is fitted with a non-adjustable, factory installed, regulator. This regulator is preset at the factory and should not be adjusted.**

**Fig. H**

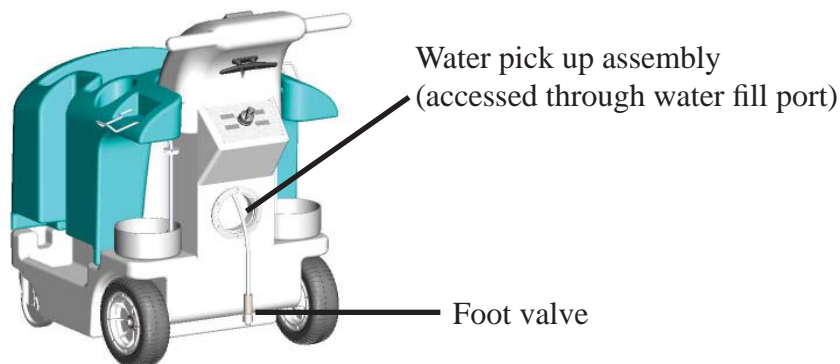

# Parts List

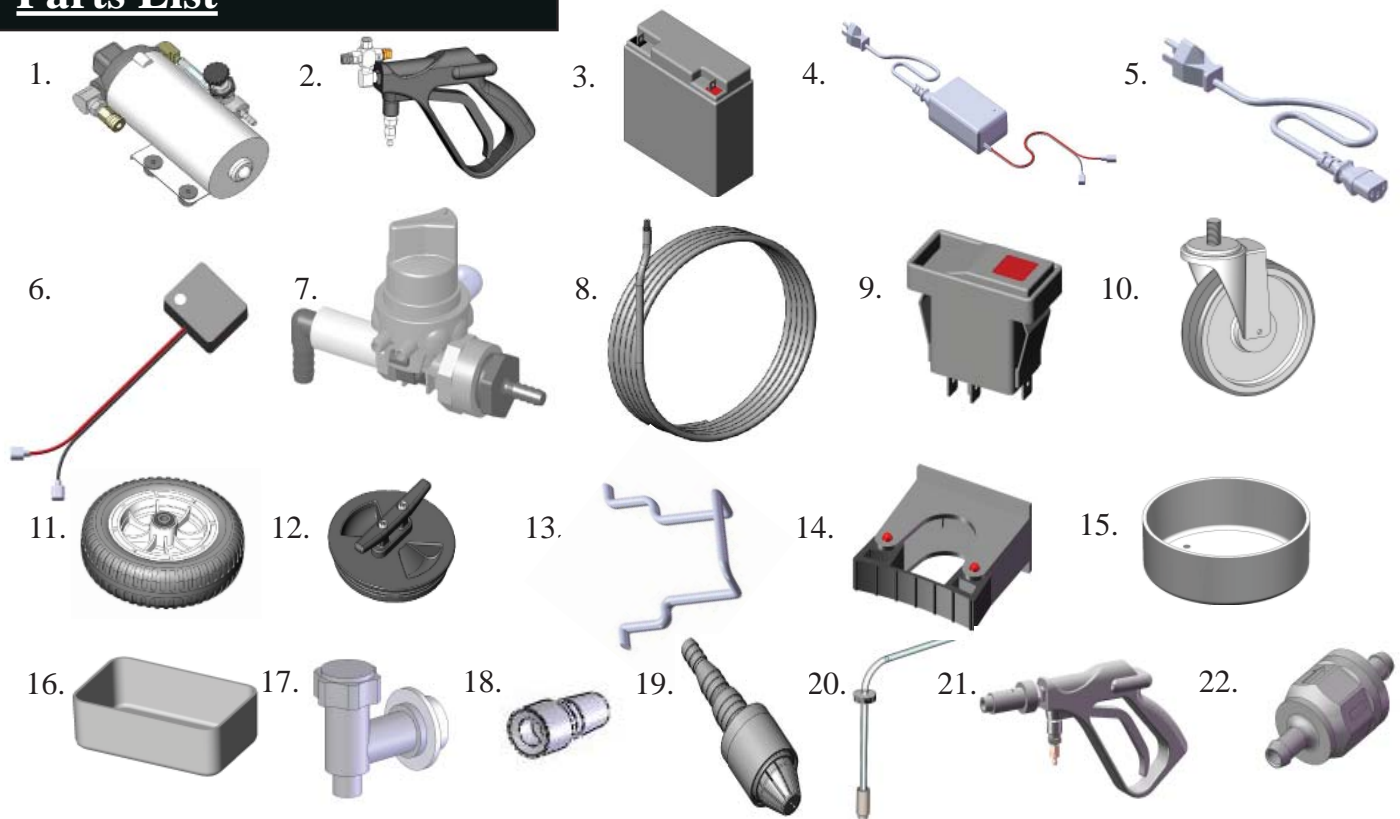

	<u>Part Number</u>	<u>Description</u>
1.	10092250	Pump Replacement Kit
2.	10091845	Spray Attachment
3.	10092253	Battery
4.	10092254	Battery Charger
5.	10092211	Cord, Battery Charger
6.	10092255	Battery life indicator
7.	10092262	Chemical selector valve
8.	10091864	Discharge hose replacement, black
9.	10092252	On/off switch replacement kit
10.	10091867	Caster replacement kit (set of 2)
11.	10091866	Wheel replacement kit (set of 2)
12.	10091861	Fill port cap
13.	10092217	Sign hanger
14.	10092258	Mop clips (set of 2)
15.	10092256	Bottle holder (round) - (set of 2)
16.	10092257	Bottle holder (rectangular) - (set of 2)
17.	90084615	Tap style drain
18.	690014	Metering tip kit
19.	10076302	Foot valve, EPDM
20.	10092251	Chemical feed line kit
21.	10092259	Optional foaming attachment
22.	10069255	Check Valve