

**Troubleshooting Chart:**

Problem	Cause	Solution
1. No discharge	a. No water b. Magnetic valve not functioning c. Excessive water pressure  d. Eductor clogged e. Clogged water inlet strainer	a. Open water supply b. Install valve parts kit c. Install regulator if water pressure exceeds 60 PSI (flowing) d. Clean* or replace e. Disconnect inlet water line and clean s strainer
2. No concentrate draw	a. Clogged foot valve b. Metering tip or eductor has scale build-up c. Low water pressure  d. Discharge tube and/or flooding ring not in place  e. Concentrate container empty f. Inlet hose barb not screwed into eductor tightly g. Clogged water inlet strainer h. Air leak in chemical pick-up tube	a. Clean or replace b. Clean (descale)* or replace  c. Minimum 20 PSI (with water running) required to operate unit properly d. Push tube firmly onto eductor discharge hose barb, or replace tube if it doesn't have a flooding ring. e. Replace with full container f. Tighten, but do not overtighten  g. Disconnect inlet water line and clean strainer h. Put clamp on tube or replace tube if brittle
3. Excess concentrate draw	a. Metering tip not in place b. Chemical above eductor	a. Press correct tip firmly into barb on eductor b. Place concentrate below the eductor
4. Failure of unit to turn off	a. Water valve parts dirty or defective b. Magnet doesn't fully return c. Push button stuck	a. Clean* or replace with valve parts kit b. Make sure magnet moves freely. c. Remove button and clean cabinet/button to remove any dirt lodged in slide recess
5. Excess foaming in discharge	a. Air leak in pick-up tube	a. Put clamp on tube or replace tube if brittle

\* In hard water areas, scale may form inside the discharge end of the eductor, as well as in other areas of the unit that are exposed to water. This scale may be removed by soaking the eductor in a descaling solution (deliming solution). To remove an eductor located in the cabinet, firmly grasp water valve and unthread eductor. Replace in same manner. Alternatively, a scaled eductor can be cleaned (or kept from scaling) by drawing the descaling solution through the unit. Operate the unit with the suction tube in the descaling solution. Operate the unit until solution is drawn consistently, then flush the unit by drawing clear water through it for a minute. Replace concentrate container and put suction tube into concentrate.



**Streamline Series  
Push-button Proportioner  
with E-Gap Eductors  
8681BA**

**Package Contains:**

1. Proportioner unit.
2. Supply tube — 7 ft. per eductor.
3. Foot valve(s) and weight(s).
4. Discharge tube(s).
5. Metering tip kit(s).
6. Mounting anchor kit.

**THANK YOU FOR YOUR INTEREST IN OUR PRODUCTS**

Hydro Systems manufactures quality chemical proportioning equipment. Please use this equipment carefully and observe all warnings and cautions.

\*\*\*\*\* NOTE \*\*\*\*\*

<b>WEAR</b>	protective clothing and eyewear when dispensing chemicals or other materials.
<b>ALWAYS</b>	observe safety and handling instructions of the chemical manufacturers.
<b>ALWAYS</b>	direct discharge away from you or other persons or into approved containers.
<b>ALWAYS</b>	dispense cleaners and chemicals in accordance with manufacturer's instructions. Exercise <b>CAUTION</b> when maintaining your equipment.
<b>KEEP</b>	equipment clean to maintain proper operation.
<b>WEAR</b>	protective clothing and eyewear when working in the vicinity of all chemicals, filling or emptying equipment or changing metering tips.
<b>ALWAYS</b>	re-assemble equipment according to instruction procedures. Be sure all components are firmly screwed or latched into position.
<b>ATTACH</b>	only to tap water outlets (85 PSI maximum).
<b>NOTE</b>	If the unit is used to fill a sink or the discharge hose can be placed into a sink, the unit must be mounted so that the bottom of the cabinet is above the overflow rim of the sink.

**Installation and Operation:**

Repeat the following procedures as necessary for the number of eductors your unit contains.

1. Remove cabinet screws and cover. Drill holes for the three wall anchors with a 9/32" drill, using the cabinet back as a template for proper spacing of the mounting screws. Install mounting anchors, and then screws in top two anchors. Slide key holes in cabinet back over screw heads. Tighten screws and install third (bottom) screw. Do not mount more than 6 ft. (1.8 m) above bottom of concentrate container, nor below the highest concentrate level (never mount your concentrate higher than the *Streamline* unit).
2. Select a metering tip for each eductor and insert the tip into the hose barb on the eductor body.
3. Supply tube should reach from hose barb on eductor to bottom of concentrate container. If using more than one eductor, cut supply tube provided to lengths required. Slide ceramic weight over one end of the tube and slide foot valve into the same end of the tube.
4. Slip open end of supply tube through an opening in either side of the cabinet and push over the hose barb/metering tip on the eductor.
5. A short discharge tube is used with 1 GPM (grey) eductors; minimum tube length is 8" (20 cm) for proper operation. Longer (4 ft.) tubes are used with 3.5 GPM (yellow) eductors. Do not remove the flooding rings from inside the tubes. Slide end of tube with flooding ring over eductor discharge outlet. Hooks on opposite end of longer tubes are provided to allow discharge tube to conveniently hang from the side cabinet openings. Hang up the discharge tube after each usage to prevent continuous siphoning of concentrate.
6. Place foot valve end of supply tube into concentrate container. REMEMBER TO CHECK FOOT VALVE STRAINER PERIODICALLY FOR CLOGGING: CLEAN IF NECESSARY.
7. Replace cabinet cover and screws.
8. Connect water supply hose of at least 1/2" ID to water inlet swivel. (Minimum 25 PSI pressure, with water running, is required for proper operation.) Connect other end of hose to water supply. Turn on water supply.
9. Push button to start flow of desired water/concentrate solution, and hold until supply tube is primed (filled). Then push the button whenever dispensing is desired, and release button to stop flow of solution. Optional twist-to-latch buttons are available for continuous dispensing without holding button.



A **DOVER** RESOURCES COMPANY

**Metering Tip Selection:**

The final concentration of the dispensed liquid is related to both the size of the metering tip opening and the viscosity of the liquid being siphoned. If product viscosity is noticeably greater than that of water, consult the procedure for Measurement of Concentration on the next page to achieve your desired water-to-product ratio. For water-thin products, use the chart on the next page as a **guideline**. Because such factors as inlet water pressure and temperature can affect dilution ratios, the figures listed on the chart are only approximate. Test the actual dilution you are achieving using the Measurement of Concentration procedure for best results. Use the undrilled, clear tip for drilling a size not listed.

**Measurement of Concentration:**

You can determine the dispensed water-to-product ratio for any metering tip size and product viscosity. All that is required is to operate the primed dispenser for a minute or so and note two things: the amount of dispensed solution, and the amount of concentrate used in preparation of the solution dispensed. The water-to-product ratio is then calculated as follows:

Dilution Ratio (X:1) where

$$X = \frac{\text{Amount of Mixed Solution} - \text{Amount of Concentrate Drawn}}{\text{Amount of Concentrate Drawn}}$$

Dilution Ratio, then, equals X parts water to one part concentrate (X:1). If the test does not yield the desired ratio, choose a different tip and repeat the test. Alternative methods to this test are 1) pH (using litmus paper), and 2) titration. Contact your concentrate supplier for further information on these alternative methods and the materials required to perform them.

**Streamline Parts Diagram:**

3-button unit illustrated

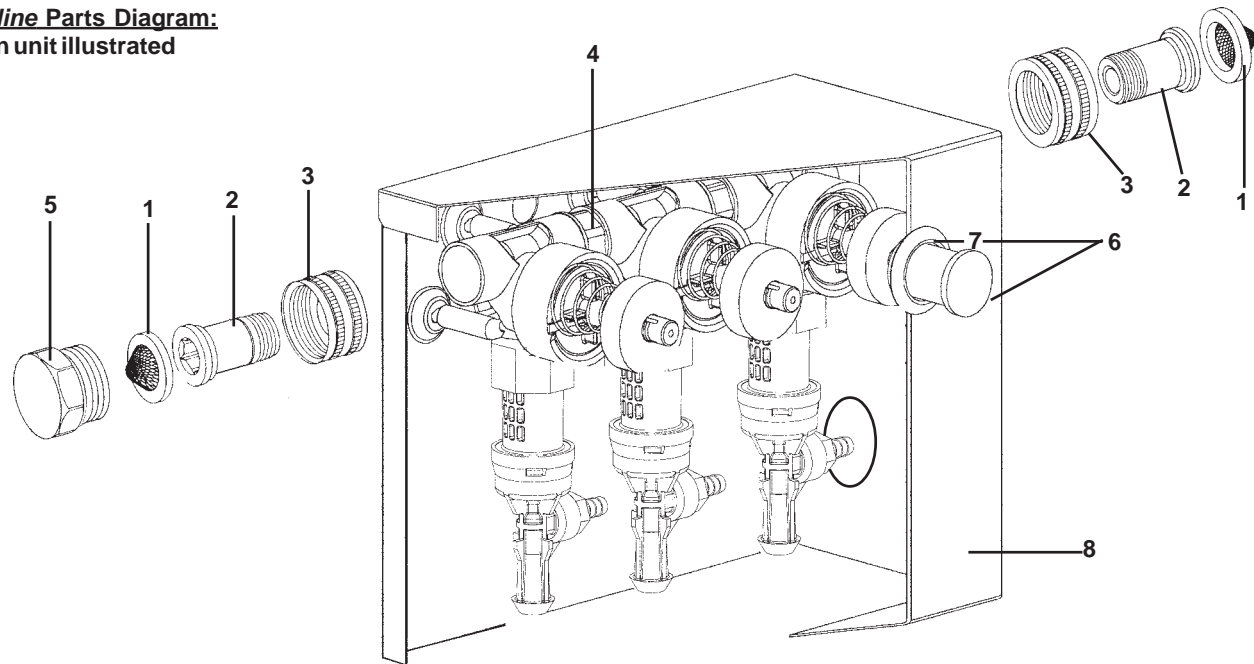

Tip Color	Orifice Size	Std. Drill Number	Ratio (per Eductor Flow)	
			1 GPM	3.5 GPM
No Tip	.187	(3/16)	3:1	3.5:1
Grey	.128	(30)	3:1	4:1
Black	.098	(40)	3:1	4:1
Beige	.070	(50)	4:1	8:1
Red	.052	(55)	5:1	14:1
White	.043	(57)	7:1	20:1
Blue	.040	(60)	8:1	24:1
Tan	.035	(65)	10:1	30:1
Green	.028	(70)	16:1	45:1
Orange	.025	(72)	20:1	56:1
Brown	.023	(74)	24:1	64:1
Yellow	.020	(76)	32:1	90:1
Aqua	.018	(77)	38:1	128:1
Purple	.014	(79)	64:1	180:1
Pink	.010	(87)	128:1	350:1

**Streamline Parts Diagram/List:**

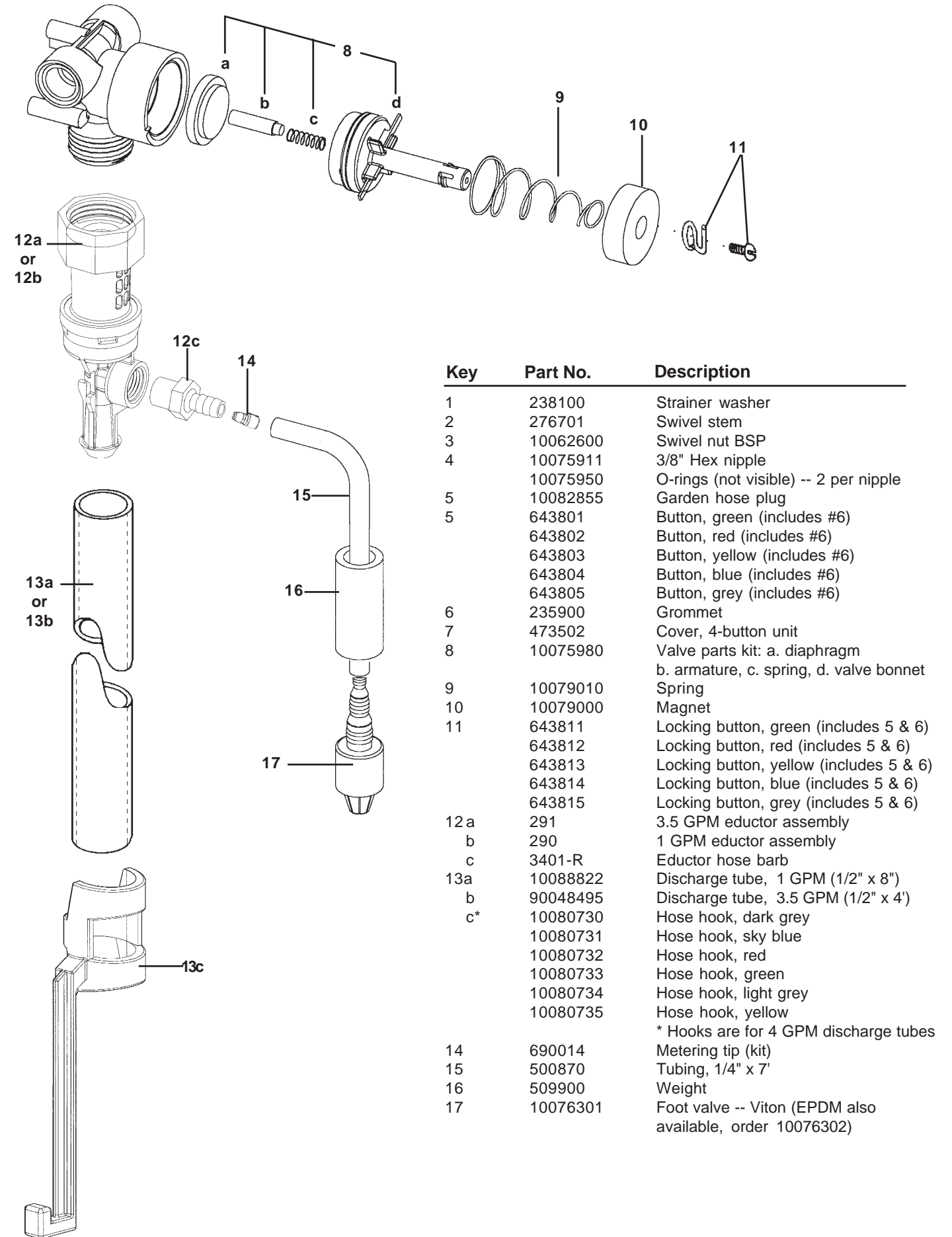

Key	Part No.	Description
1	238100	Strainer washer
2	276701	Swivel stem
3	10062600	Swivel nut BSP
4	10075911	3/8" Hex nipple
5	10075950	O-rings (not visible) -- 2 per nipple
5	10082855	Garden hose plug
	643801	Button, green (includes #6)
	643802	Button, red (includes #6)
	643803	Button, yellow (includes #6)
	643804	Button, blue (includes #6)
	643805	Button, grey (includes #6)
6	235900	Grommet
7	473502	Cover, 4-button unit
8	10075980	Valve parts kit: a. diaphragm b. armature, c. spring, d. valve bonnet
9	10079010	Spring
10	10079000	Magnet
11	643811	Locking button, green (includes 5 & 6)
	643812	Locking button, red (includes 5 & 6)
	643813	Locking button, yellow (includes 5 & 6)
	643814	Locking button, blue (includes 5 & 6)
	643815	Locking button, grey (includes 5 & 6)
12 a	291	3.5 GPM eductor assembly
b	290	1 GPM eductor assembly
c	3401-R	Eductor hose barb
13a	10088822	Discharge tube, 1 GPM (1/2" x 8")
b	90048495	Discharge tube, 3.5 GPM (1/2" x 4')
c*	10080730	Hose hook, dark grey
	10080731	Hose hook, sky blue
	10080732	Hose hook, red
	10080733	Hose hook, green
	10080734	Hose hook, light grey
	10080735	Hose hook, yellow
		* Hooks are for 4 GPM discharge tubes
14	690014	Metering tip (kit)
15	500870	Tubing, 1/4" x 7'
16	509900	Weight
17	10076301	Foot valve -- Viton (EPDM also available, order 10076302)